



SmartGen[®]
ideas for power

SGQ_ATS

Automatic Transfer Switch

USER MANUAL

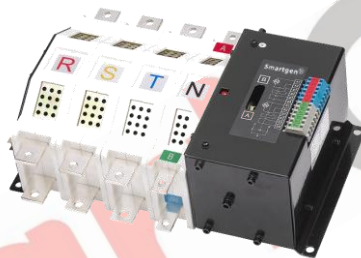

SMARTGEN (ZHENGZHOU) TECHNOLOGY CO., LTD.

CONTENTS

1	SUMMARY	4
2	STRUCTURE AND CHARACTERISTICS	4
3	APPEARANCE AND CLASSIFICATION	5
3.1	N TYPE CASE DIMENSIONS AND TECHNICAL DATA	6
3.2	T TYPE CASE DIMENSIONS AND TECHNICAL DATA.....	7
3.3	M TYPE CASE DIMENSIONS AND TECHNICAL DATA.....	8
3.4	Q TYPE CASE DIMENSIONS AND TECHNICAL DATA.....	9
4	WORKING REQUIREMENTS	10
5	ATS WIRING CONNECTION DIAGRAM.....	10
5.1	N AND T TYPE WIRING CONNECTION DIAGRAM.....	10
5.2	M TYPE WIRING CONNECTION DIAGRAM.....	11
5.3	Q TYPE WIRING CONNECTION DIAGRAM.....	11
6	INSTALLATION AND DEBUGGING	12
7	PURCHASE MODEL EXPLANATION	12

SmartGen

1 SUMMARY

SGQ Automatic Transfer Switch (ATS) is used under conditions of AC660V 50/60Hz or DC250V. It is two-stage PC class type with electromagnetism drive structure, which can make fast load transfer (transfer time $\leq 80\text{ms}$) of two power circuits. It can be widely used for national one-class load, for example: high buildings, post, telecommunications, coal mines, ships, industrial assembly lines, health care, military facilities etc. The two power circuits can be grid, auto start genset, storage battery etc.

2 STRUCTURE AND CHARACTERISTICS

SGQ Automatic Transfer Switch (ATS) adopts electromagnetic coil drive, electrical and mechanical interlocking structure, main loop structure of two static contacts and one dynamic contact. Dynamic contact applies V type, which ensures two power circuits shall not be short circuit. N type and T type applies double coils; M type and Q type applies single coil. Coils only are energized at the time of transfer and this extends the usage life of switch to a great degree. Coil control power can be supplied by master/slave AC or DC power and it is not needed to add another control power. Switch itself has mechanical or electrical close indication, and at the same time it provides volts free auxiliary contact.

3 APPEARANCE AND CLASSIFICATION

SGQ ATS can be classified into 4 types by appearance: N type, T type, M type and Q type. Each type has 3P and 4P, and N type still has 2P.

The rated current series are: 63A, 125A, 160A, 200A, 250A, 400A, 630A, 800A, 1000A and 1250A, 1600A, 2000A, 2500A and 3200A.

Switch appearances are as below.

Table 2 Switch Appearance

Type	2P	3P	4P
N Type			
	63A, 125A		
T Type	Nil		
	160A, 200A, 250A, 400A, 630A		
M Type	Nil		
	630A, 800A, 1000A, 1250A		
Q Type	Nil		
	1600A, 2000A, 2500A, 3200A		

3.1 N TYPE CASE DIMENSIONS AND TECHNICAL DATA

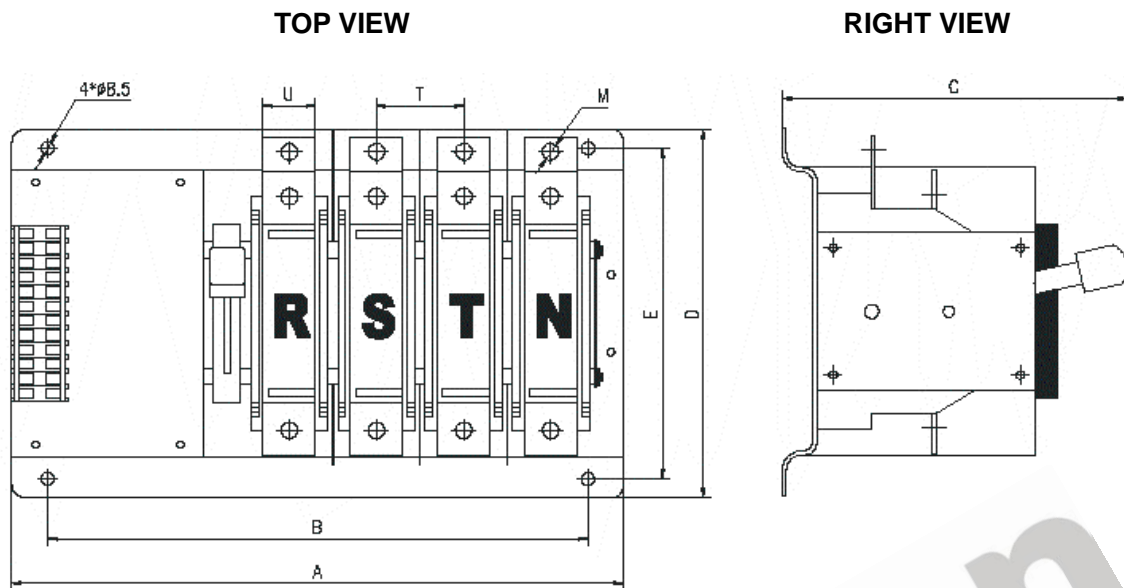

Fig. 1 N Type Diagram

Table 3 N Type Case Dimensions

Model	Overall size(mm)					Installation size(mm)				Copper bar and location hole (mm)		
	A			D	C	B			E	M	U	T
	2P	3P	4P			2P	3P	4P				
SGQ63N	172	200	228	186	155	139	167	195	165	5	12	27
SGQ125N	192	228	265	186	155	159	195	232	165	7	20	37

Table 4 N Type Technical Data

Type		SGQ63N			SGQ125N		
Rated current		63A			125A		
Rated limited short-circuit current		35kA			35kA		
Coil operating voltage		AC220V(176~265)V			AC220V(176~265)V		
Coil operating current		3.5A			3.5A		
Secondary contact		1A 250VAC, N/O, Free Voltage, Each side has 2.			1A 250VAC, N/O, Free Voltage, Each side has 2.		
Operation time	Mechanical	10000 times			10000 times		
	Electrical	4000 times			4000 times		
Number of poles		2P	3P	4P	2P	3P	4P
Net weight (kg)		3.5	4	4.5	4	4.5	5.5
Operation cycle		15 seconds/time			15 seconds/time		

3.2 T TYPE CASE DIMENSIONS AND TECHNICAL DATA

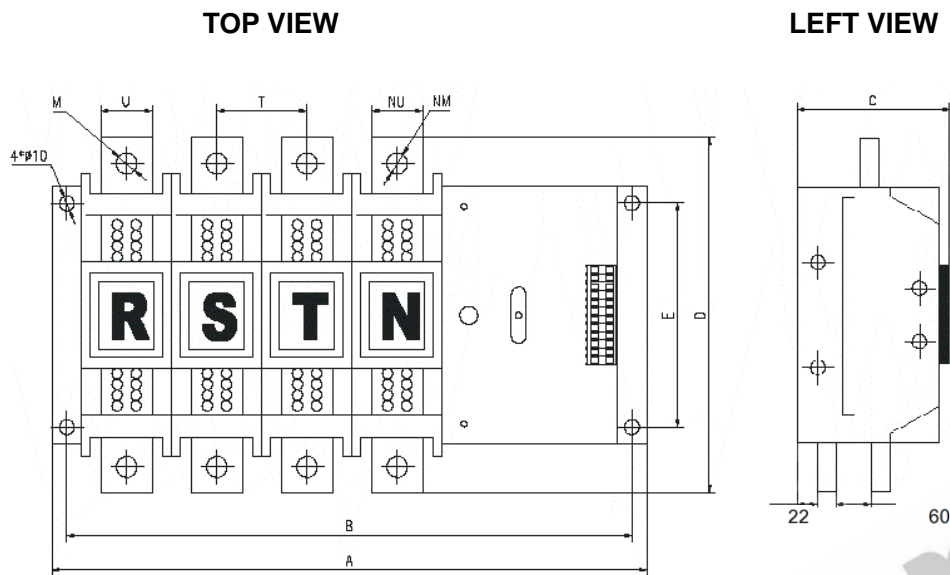

Fig. 2 T Type Diagram

Table 5 T Type Case Dimensions

Model	Overall size(mm)				Installation size (mm)			Copper bar and location hole (mm)				
	A		D	C	B		E	M	NM	U	NU	T
	3P	4P			3P	4P						
SGQ160T	326	375	292	146	307	356	200	9	9	20	20	49
SGQ200T	326	375	292	146	307	356	200	9	9	20	20	49
SGQ250T	326	375	292	146	307	356	200	9	9	20	20	49
SGQ400T	356	405	292	146	337	386	200	11	9	30	20	59
SGQ630T	368	427	310	146	349	408	200	14	14	40	30	63

Table 6 T Type Technical Data

Type		SGQ160T	SGQ200T	SGQ250T	SGQ400T	SGQ630T					
Rated current		160A	200A	250A	400A	630A					
Rated limited short-circuit current		35kA									
Coil operating voltage		AC220V (176~265)V									
Coil operating current		7A									
Auxiliary contact		1A 250VAC, N/O, Free Voltage, Each side has 2.									
Operation time	Mechanical	8000 times									
	Electrical	3000 times									
Number of poles		3P	4P	3P	4P	3P	4P	3P	4P	3P	4P
Net weight (kg)		18	20	18	20	18	20	19	21	20	22
Operation cycle		10 seconds/ time									

3.3 M TYPE CASE DIMENSIONS AND TECHNICAL DATA

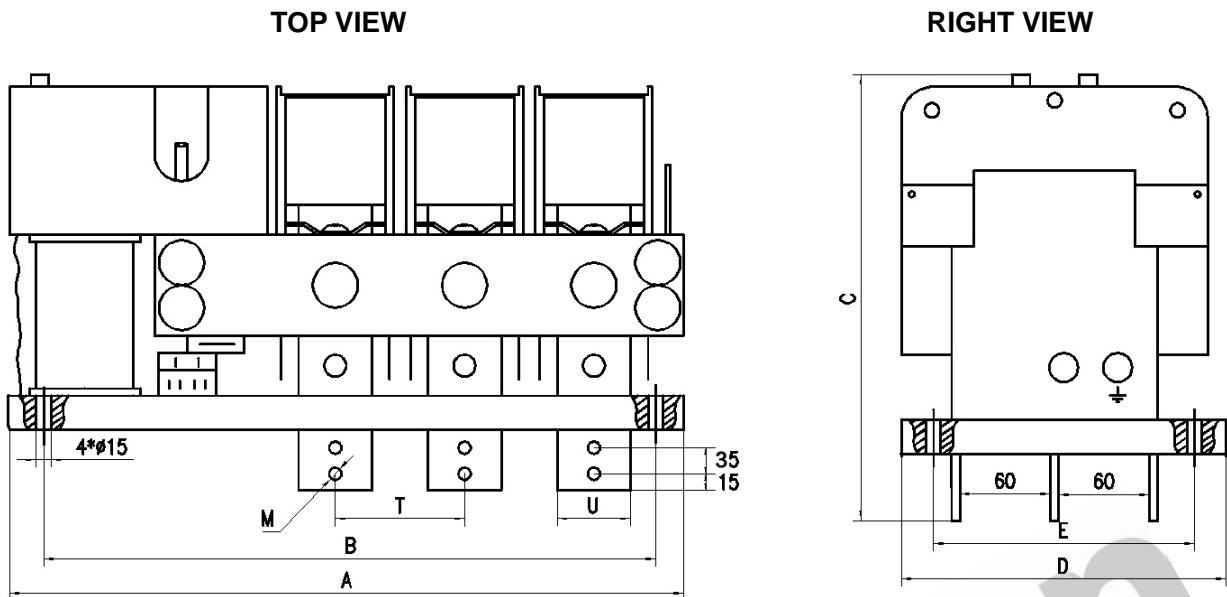

Fig. 3 M Type Diagram

Table 7 M Type Case Dimensions

Models	Overall size(mm)				Installation size(mm)			Copper bar and location hole (mm)		
	A		D	C	B		E	M	U	T
	3P	4P			3P	4P				
SGQ630M	530	600	280	345	490	560	210	12	30	90
SGQ800M	530	600	280	345	490	560	210	12	40	90
SGQ1000M	530	600	280	345	490	560	210	12	45	90
SGQ1250M	530	600	280	345	490	560	210	12	55	90

Table 8 M Type Technical Data

Type		SGQ630M	SGQ800M	SGQ1000M	SGQ1250M				
Rated current		630 A	800 A	1000 A	1250 A				
Rated limited short-circuit current		50 kA							
Coil operating voltage		AC220V (176~265)V							
Coil operating current		16A							
Secondary contact		1A 250VAC, N/O, Free Voltage, Each side has 1.							
Operation time	Mechanical	6000 times							
	Electrical	3000 times							
Number of poles		3P	4P	3P	4P	3P	4P	3P	4P
Net weight (kg)		37	43.5	39	46	41	48	48	57
Operation cycle		15 s/time		20 s/time		25 s/time		25 s/time	

3.4 Q TYPE CASE DIMENSIONS AND TECHNICAL DATA

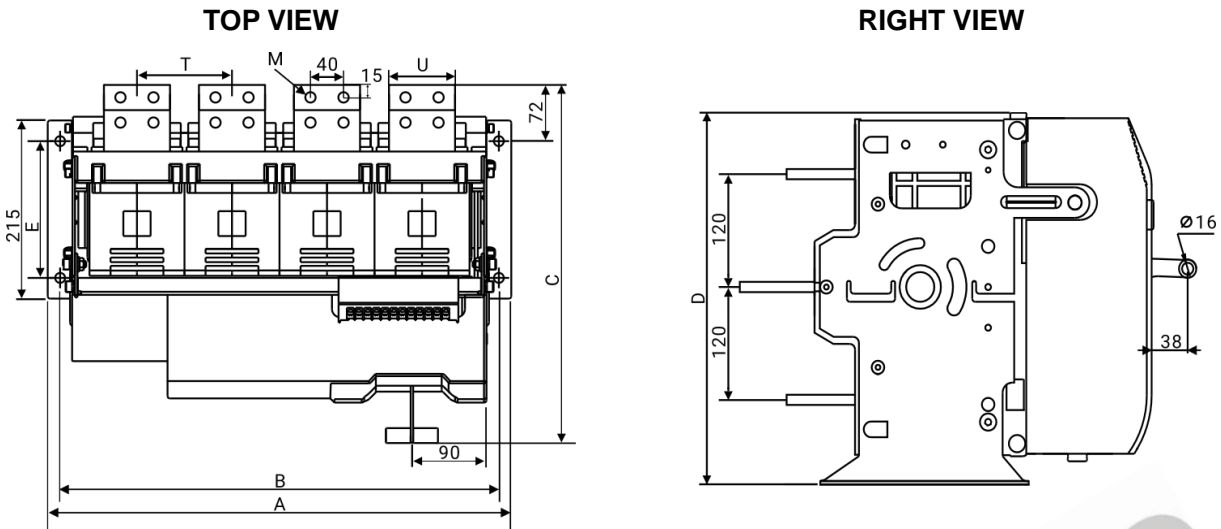

Fig. 4 Q Type Diagram

Table 9 Q Type Case Dimensions

Models	Overall size(mm)				Installation size(mm)			Copper bar and location hole (mm)		
	A		D	C	B		E	M	U	T
	3P	4P			3P	4P				
SGQ1600Q	445	561	392	438	415	531	165	13	80	115
SGQ2000Q	445	561	392	438	415	531	165	13	80	115
SGQ2500Q	445	561	392	438	415	531	165	13	80	115
SGQ3200Q	445	561	392	438	415	531	165	13	80	115

Table 10 Q Type Technical Data

Type	SGQ1600Q	SGQ2000Q	SGQ2500Q	SGQ3200Q
Rated current	1600 A	2000 A	2500 A	3200 A
Rated limited short-circuit current	50 kA			
Coil operating voltage	AC220V (176~265)V			
Coil operating current	16A			
Secondary contact	1A 250VAC, N/O, Free Voltage, Each side has 1.			
Operation time	Mechanical	6000 times		
	Electrical	3000 times		
Number of poles	3P	4P	3P	4P
Net weight (kg)	45	54	58	68
Operation cycle	25 s/time			

4 WORKING REQUIREMENTS

Table 11 Working Requirements

Item	Requirements
Ambient temperature	(-5~+45)°C
Humidity	(20~90)%
Installation elevation	≤2000 m
Pollution class	III
Installation type	IV

5 ATS WIRING CONNECTION DIAGRAM

5.1 N AND T TYPE WIRING CONNECTION DIAGRAM

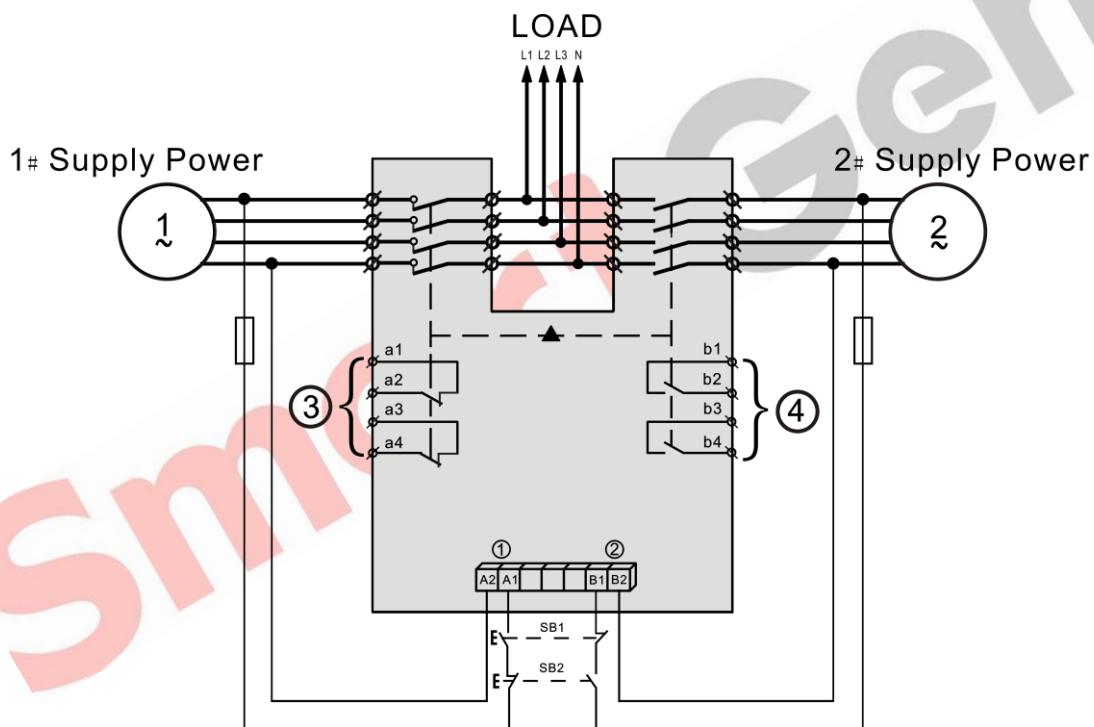

Fig. 5 N Type and T Type

- | | |
|-------------------------------|--------------------------------|
| 1. Position control I | 2. Position control II |
| 3. Aux. contact of position I | 4. Aux. contact of position II |
| SB1 is #1 power close button | SB2 is #2 power close button |

5.2 M TYPE WIRING CONNECTION DIAGRAM

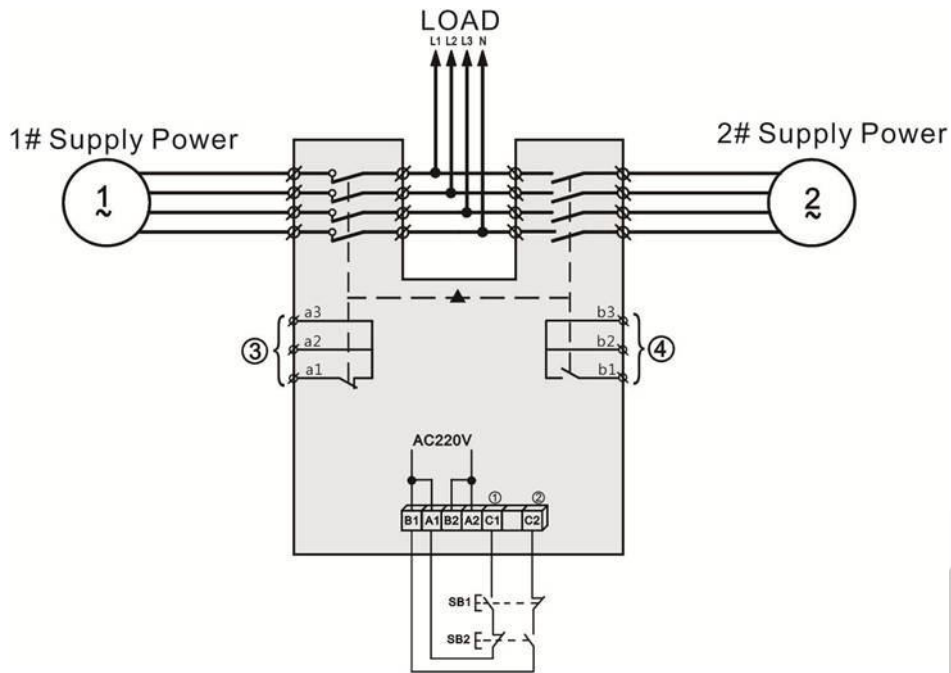

Fig. 6 M Type

- | | |
|-------------------------------|--------------------------------|
| 1. Position control I | 2. Position control II |
| 3. Aux. contact of position I | 4. Aux. contact of position II |
| SB1 is #1 power close button | SB2 is #2 power close button |

5.3 Q TYPE WIRING CONNECTION DIAGRAM

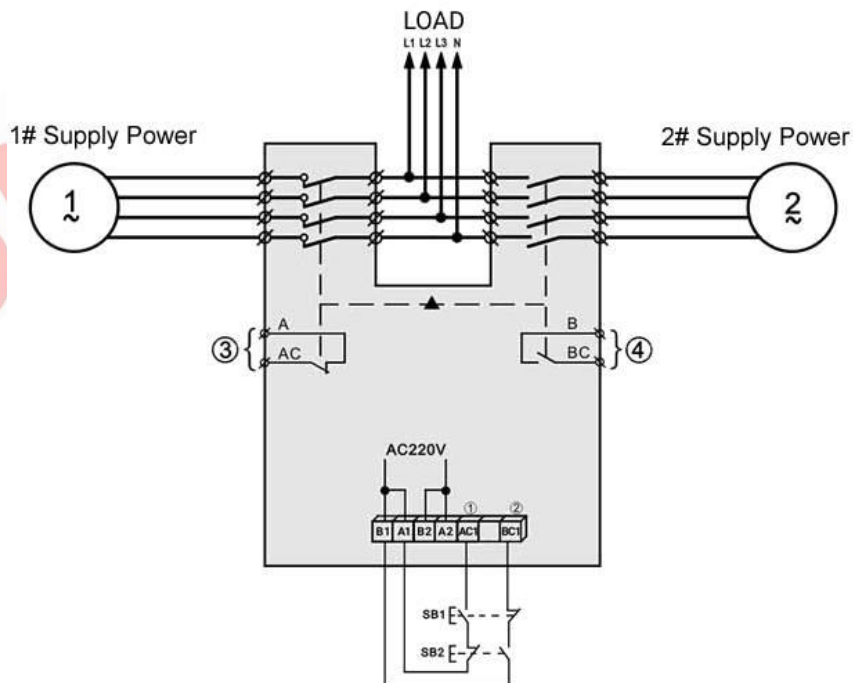

Fig. 7 Q Type

- | | |
|-------------------------------|--------------------------------|
| 1. Position control I | 2. Position control II |
| 3. Aux. contact of position I | 4. Aux. contact of position II |
| SB1 is #1 power close button | SB2 is #2 power close button |

6 INSTALLATION AND DEBUGGING

All operations about ATS installation and debugging shall be conducted by professionals or persons knowing the switch device and protection and precaution measures must be considered during the operation. Wiring connection of main loop must make sure leading wire is not taking any pressure or force. Before installation and debugging please check firstly whether switch is damaged or whether there is harmful environment effect on it. At the same time please check whether there is loose wire resulting from transportation; clear the smudginess, especially the smudginess on the surface of insulating parts. The smudginess probably is caused by the packing materials in the transportation process or in the storage process. Please make sure the phase sequences are in accordance at connecting the first circuit; please observe the wiring connection diagram of user manual strictly at connecting the second circuit and pay attention to control power voltage class at the same time. Ground must be well connected on switch installation. Considering personal safety and switch changeover rapidity, debugging handle can only be used for debugging and users are prohibited to operate on-load with debugging handle. First use the handle to operate switch, and if nothing unusual occurs, then operate button manually. If nothing unusual happens, then normal running can start.

7 PURCHASE MODEL EXPLANATION

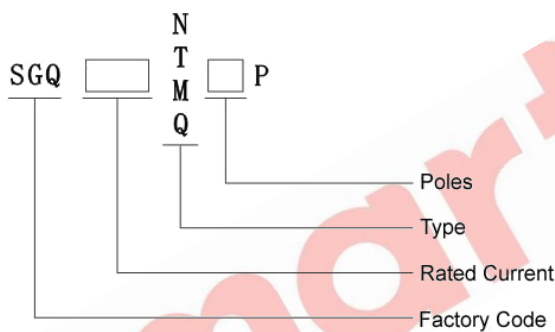

Fig. 8 Model Illustration