

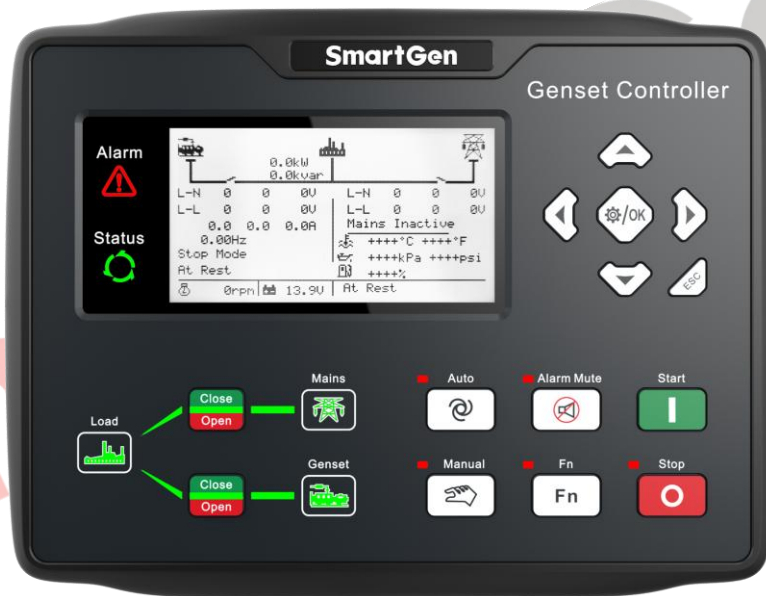





**SmartGen**  
ideas for power

# HGM9420N\_HGM9420LT GENSET CONTROLLER USER MANUAL



**SMARTGEN (ZHENGZHOU) TECHNOLOGY CO.,LTD.**

**Table 2 Symbol Instruction**

Symbol	Instruction
 NOTE	Highlights an essential element of a procedure to ensure correctness.
 CAUTION	Indicates a procedure or practice, which, if not strictly observed, could result in damage or destruction of equipment.
 WARNING	Indicates a procedure or practice, which could result in injury to personnel or loss of life if not followed correctly.

SmartGen

# CONTENTS

1	OVERVIEW .....	6
2	PERFORMANCE AND CHARACTERISTICS .....	7
3	SPECIFICATION.....	10
4	OPERATION .....	12
4.1	INDICATOR LAMP .....	12
4.2	PUSHBUTTONS.....	13
4.3	LCD DISPLAY .....	14
4.3.1	MAIN DISPLAY .....	14
4.3.2	USER MENU AND PARAMETER SETTING.....	16
4.4	AUTO START/STOP OPERATION.....	18
4.4.1	ILLUSTRATION.....	18
4.4.2	AUTOMATIC START SEQUENCE .....	18
4.4.3	AUTOMATIC STOP SEQUENCE .....	19
4.5	MANUAL START/STOP OPERATION.....	19
5	CONTROLLER SWITCH CONTROL PROCEDURES.....	20
5.1	SWITCH CONTROL PROCEDURE FOR SYNC TRANSFER DISABLED .....	20
5.1.1	MANUAL TRANSFER PROCESS .....	20
5.1.2	AUTOMATIC TRANSFER PROCEDURE.....	20
5.2	SWITCH CONTROL PROCEDURE FOR SYNCHRONOUS TRANSFER ENABLED .....	21
5.2.1	MANUAL TRANSFER PROCEDURE.....	21
5.2.2	AUTO SWITCHING PROCESS .....	22
6	PROTECTIONS .....	25
6.1	WARNING ALARMS.....	25
6.2	BLOCK ALARMS.....	32
6.3	TRIP ALARM .....	38
6.4	TRIP AND STOP ALARMS .....	43
6.5	SHUTDOWN ALARMS.....	50
7	WIRING CONNECTION .....	56
8	SCOPES AND DEFINITIONS OF PROGRAMMABLE PARAMETERS .....	59
8.1	CONTENTS AND SCOPES OF PARAMETERS.....	59
8.2	ENABLE DEFINITION OF PROGRAMMABLE OUTPUT PORTS .....	77
8.2.1	DEFINITION OF DIGITAL OUTPUT PORTS.....	77
8.2.2	DEFINED PERIOD OUTPUT .....	85
8.2.3	DEFINED COMBINATION OUTPUT .....	85
8.3	DEFINED CONTENTS OF PROGRAMMABLE INPUT PORTS .....	86
8.4	SELECTION OF SENSORS.....	89
8.5	CONDITIONS OF CRANK DISCONNECT SELECTION.....	90
9	PARAMETERS SETTING.....	90
10	CYCLE START .....	91
11	SENSOR SETTING .....	91

12	COMMISSIONING .....	93
13	TYPICAL APPLICATION .....	94
14	NEL TRIP DESCRIPTION .....	96
15	DUMMY LOAD CONNECTION .....	97
16	OIL CONSUMPTION ILLUSTRATION .....	98
17	ETHERNET PORT .....	98
18	HOST USB PORT .....	99
19	INSTALLATION.....	99
19.1	SGE02 EXPANSION MODULE.....	99
19.1.1	4G ANTENNA PORT .....	99
19.1.2	GPS ANTENNA PORT.....	99
19.1.3	SIM CARD INSTALLATION .....	100
19.2	CASE DIMENSIONS AND CUTOUT SIZE .....	100
20	SMS MESSAGE ALARM AND REMOTE CONTROL.....	102
20.1	SMS MESSAGE ALARM.....	102
20.2	SMS MESSAGE REMOTE CONTROL.....	102
21	CONNECTIONS OF CONTROLLER AND J1939 ENGINE .....	103
21.1	CUMMINS ISB/ISBE.....	103
21.2	CUMMINS QSL9 .....	103
21.3	CUMMINS QSM11 (IMPORT).....	104
21.4	CUMMINS QSX15-CM570 .....	104
21.5	CUMMINS GCS-MOVBUS.....	105
21.6	CUMMINS QSM11 .....	105
21.7	CUMMINS QSZ13 .....	105
21.8	DETROIT DIESEL DDEC III/IV .....	106
21.9	DEUTZ EMR2.....	106
21.10	JOHN DEERE.....	106
21.11	MTU MDEC.....	107
21.12	MTU ADEC(SMART MODULE) .....	107
21.13	MTU ADEC (SAM MODULE) .....	107
21.14	PERKINS .....	108
21.15	SCANIA.....	108
21.16	VOLVO EDC3.....	108
21.17	VOLVO EDC4.....	109
21.18	VOLVO-EMS2 .....	109
21.19	YUCHAI .....	110
21.20	WEICHAI.....	110
22	FAULT FINDING .....	111
23	APPENDIX .....	112

## 1 OVERVIEW

**HGM9420N\_HGM9420LT** genset controller is used for automatic control of single genset to realize automatic start/AMF/synchronous transfer/cloud monitoring. This series of controller integrates digitalization, intelligence, and network technology. It fits with LCD graphic display, optional Chinese, English and other languages interface, and it is reliable and easy to use.

**HGM9420N\_HGM9420LT** genset controller applies 32-bit microprocessor technology, realizing precise measuring of many parameters, value adjusting, and timing, threshold adjusting etc. functions. A majority of parameters can be adjusted from the front panel. All parameters can be adjusted via USB or RS485 port on PC. Controller fits with SAE J1939 port, which can communicate with multiple ECU (ENGINE CONTROL UNIT) units with J1939. With compact structure, simple wiring, and high reliability, it can be used in various genset automation systems.

**HGM9420N\_HGM9420LT** genset controller can connect with SGE02-4G network communication expansion module, which can make genset connected with Internet. After controller is logged in cloud server, it can upload the data information (includes: GPS positioning site, altitude etc.) at real time to the corresponding cloud server. Users can monitor and check genset running status and event log at real time by mobile APP (IOS or Android), or PC similar terminal device. Network communication module has SMS message function.

## 2 PERFORMANCE AND CHARACTERISTICS

**HGM9420N\_HGM9420LT:** fits Mains-Gen power monitoring for Mains/Gen automatic transfer control (AMF). It is used for single unit automation system formed by one Mains and one Genset. Mains can be disabled by disabling mains parameters for single unit automation. By remote start signal genset auto start and stop can be controlled. Mains can be enabled only by setting mains parameters to realize mains parameter only display; by remote start signal genset auto start and stop can be controlled. Synchronous transfer function can be enabled to realize Gen and Mains synchronous transfer function. Main characteristics are as below:

- 240x128 LCD with backlight, multilingual interface (including English, Chinese or other languages) which can be chosen at the site, making commissioning convenient for factory personnel; For other languages language package needs to be written by PC software;
- Language packages include: Simplified Chinese, Traditional Chinese, English, Spanish, Portuguese, Russian, Arabic, Turkish, Thai, French, Polish, German, Italian, Dutch;
- 2 RS485 and 1 RJ45 Ethernet communication port, "4 remotes" (remote control, remote measuring, remote communicating, and remote adjusting) can be realized by MODBUS protocol;
- 1 Fn function key, can be set to other function on the panel, or Fn key function;
- Suitable for 3-phase 4-wire, 3-phase 3-wire, single phase 2-wire, and 2-phase 3-wire systems with voltage 120/240V and frequency 50/60Hz;
- Collects and shows 3-phase voltage of Mains/Gen, 3-phase current, frequency, load power and Gen voltage harmonic parameters;

### Mains

Line voltage	Uab, Ubc, Uca
Phase voltage	Ua, Ub, Uc
Frequency	Hz
Phase sequence	

### Gen

Line voltage	Uab, Ubc, Uca
Phase voltage	Ua, Ub, Uc
Frequency	Hz
Phase sequence	
Harmonic wave	1-21 times harmonic content    waveform distortion

### Load

Current	Ia, Ib, Ic
Each phase and total active power	P
Reactive power	Q
Apparent power	S
Power factor	PF
Gen total energy	kWh, kvarh, kVAh
Earth current	A
Unbalanced current	A

Load output percentage	(active power/rated power)x100%
Average load of current run	kW
Total energy of current run	kWh
Average load of last time	kW
Historical max average load	kW

- Mains has over voltage, under voltage, over frequency, under frequency, loss of phase, reverse phase sequence function; Gen has over voltage, under voltage, over frequency, under frequency, over current, over power, reverse power, loss of phase, reverse phase sequence, unbalanced voltage high, waveform distortion high, earth fault, unbalanced current high, power factor low, loss of excitation detection function;
- Synchronous transfer enabled parameters: voltage difference of Gen and Mains, frequency difference of Gen and Mains, phase angle difference of Gen and Mains;
- Collect precisely various parameters of engine:
 

Temperature	Unit: °C/°F
Oil pressure	Unit: kPa/psi/bar
Fuel Level	Unit: %
Speed	Unit: r/min (RPM)
Battery voltage	Unit: V
Charger D+ voltage	Unit: V
Total run time	max 65535 hours
Total start times	max 65535 times
- Control and protection function: automatic start/stop of the diesel genset, ATS(Auto Transfer Switch) control and perfect fault indication and protection function etc.;
- Parameter setting function: parameters can be modified by users and cannot be lost even in case of power outage; most of them can be adjusted from the front panel of the controller and all of them can be modified on PC by USB, RS485 port, or RJ45 Ethernet port;
- 3 fixed analogue sensor inputs (temp., oil pressure, fuel level);
- 3 configurable sensors can be set to temp., pressure, or level sensor;
- Oil pressure sensor, level sensor, flexible sensor 1, flexible sensor 2 inputs can directly connect resistance, voltage, or current sensor; other sensor inputs can connect resistance sensor; if voltage or current type sensors need to connect, please notify us before order;
- Multiple temp., pressure, and fuel level sensor curves can be used directly, and custom sensor curve can be done;
- Multiple crank disconnect conditions (speed, engine oil pressure, gen frequency) are optional;
- Wide power supply range DC(8~35)V, suitable for different starting battery voltage environment;
- Event log, real-time clock, scheduled start & stop function (allowing to start the genset once a day/week/month with load or not); cyclic start function of two gensets is fitted;
- Alarm data record function, which allows to record the genset data of 5 alarms;



- A USB Host port, where U flash of FAT32 format can be inserted, can put controller configured parameters to the controller, or save controller parameters to the U flash; Historical data can be saved;
- Accumulative total run time of A and B and total electric energy of A and B; Users can reset it as 0 and re-accumulative the value, making convenience for users to count the total value as they wish;
- Heater, cooler and fuel pump control functions;
- Applicable for water pump genset; it can also be used as an indicating instrument (only indication, alarm, no action for relays);
- Maintenance function; 3 groups of maintenance parameters, maintenance time, pre-alarm A time, pre-alarm B time, pre-alarm time due action, and maintenance time due action can be set;
- By judging DC voltage, auto charging start function can be realized;
- Through CAN (2) port or RS485 (2) port cyclic start function of two gensets can be realized; master run time and backup run time can be set;
- Through CAN port, AIN24, AIN26-M02, AIN8, DIN16A and DOUT16B expansion module and BAC150CAN charger can be connected;
- By setting oil tank volume and oil consumption curve, residue fuel, residue run time and real-time oil consumption can be displayed;
- Monitoring data communication protocol address is customizable by users;
- PLC function is fitted;
- By connecting SGE02-4G module, wireless network can connect with cloud server;
- By connecting SGE02-4G module, SMS function can be realized; when alarms occur, it can automatically send alarm information to the pre-set 5 phone numbers; messages are also able to control genset and check genset status;
- By connecting SGE02-4G module, GPS positioning function can be realized to obtain genset location;
- Genset data can be uploaded at changing by applying network data communication protocol of JSON format; at the same time network flow are extremely reduced by using compression algorithm; when alarms occur, it can immediately upload data to the server;
- IP65 waterproof level is achieved with the help of rubber-ring gasket between shell and control fascia;
- Metal fixing clips employed to fix the controller and make it perform better under high temperature environment; Modular structure design, self-extinguishing ABS plastic shell, pluggable terminal, built-in mounting, compact structure with easy installation;



### 3 SPECIFICATION

**Table 3 Technical Specification**

Parameter	Details
Working Voltage	Range: DC8V - DC35V continuous, DC reverse connection protection Resolution: 0.1V Accuracy: 1%
Overall Consumption	<7W (Standby mode: ≤2.5W)
AC Voltage	Phase voltage Range: AC15V - AC360V (ph-N) Resolution: 0.1V Accuracy: 0.5%
	Wire voltage Range: AC30V - AC620V (ph- ph) Resolution: 0.1V Accuracy: 0.5%
AC Frequency	Range: 5Hz -75Hz Resolution: 0.01Hz Accuracy: 0.1Hz
AC Current	Rated: 5A Range: 0A – 10A Resolution: 0.1A Accuracy: 1%
Speed Sensor	Voltage Range: 1. 0 V - 24 V (RMS) Frequency Range: 5Hz – 10000Hz
Charger(D+) Voltage	Range: DC0V - DC60V continuous Resolution: 0.1V Accuracy: 1%
DC Voltage	Range: DC0V-DC100V Resolution: 0.1V Accuracy: 1%
Analog Sensor	Resistor Input Range: 0Ω- 6000Ω Resolution: 0.1 Accuracy: 1Ω(below 300Ω)
	Voltage Input Range: 0 V - 10V Resolution: 0.001V Accuracy: 1%
	Current Input Range: 0 mA - 20mA Resolution: 0.01mA

Parameter	Details
	Accuracy: 1%
Fuel Relay Output	16A 24V DC power supply output(relay output)
Crank Relay Output	16A 24V DC power supply output(relay output)
Aux. Relay Output 1	8A 24V DC power supply output (relay output)
Aux. Relay Output 2	8A 24V DC power supply output (relay output)
Aux. Relay Output 3	8A 24V DC power supply output (relay output)
Aux. Relay Output 4	16A 250V AC volt-free output
Aux. Relay Output 5	16A 250V AC volt-free output
Aux. Relay Output 6	16A 250V AC volt-free output
Aux. Output 7-10	1A DC30V transistor B- output
Digital Input 1-10	Low threshold voltage 1.2V; high limit voltage is 60V;
RS485	Isolated, half-duplex, 9600 baud rate, maximum communication length 1000m
Internet Access	Self-adapting 10/100Mbit
CAN Port	Isolated, maximum communication length 250m, Belden 9841 cable or equivalent
EMC/CE Certification	EN 61326-1: 2013
Vibration Test	5 - 8 Hz: 17 mm 8 - 100 Hz: 4g 100-500Hz: 2g IEC 60068-2-6
Shock Test	50g, 11ms, half-sine, complete shock test from three directions, and 18 times shock for each test IEC 60068-2-27
Bump Test	25g, 16ms, self-sine IEC 60255-21-2
Production Compliance	According to EN 61010-1 installation category (over voltage category) III, 300V, pollution class 2, altitude 3000m
Case Dimensions	242 mm x 186 mm x 49 mm
Panel Cutout	214mm x 160mm
Working Conditions	HGM9420N: Temperature: (-25~+70)°C      Relative Humidity: (20~93)%RH HGM9420LT: Temperature: (-40~+70)°C      Relative Humidity: (20~93)%RH
LCD Display (HGM9420LT)	Under the temperature of -40°C, after power on for 20s it can display normally; after power on for 2min, dynamic display responses normally;
Storage Conditions	HGM9420N: Temperature:(-30~+80)°C HGM9420LT: Temperature:(-45~+80)°C
Protection Level	Front Enclosure: IP65 when rubber-ring gasket is installed between the enclosure and the control screen Rear Enclosure: IP20

Parameter	Details
Insulation Intensity	Apply AC2.2kV voltage between high voltage terminal and low voltage terminal and the leakage current is not more than 3mA within 1min.
Weight	0.91kg

## 4 OPERATION

### 4.1 INDICATOR LAMP

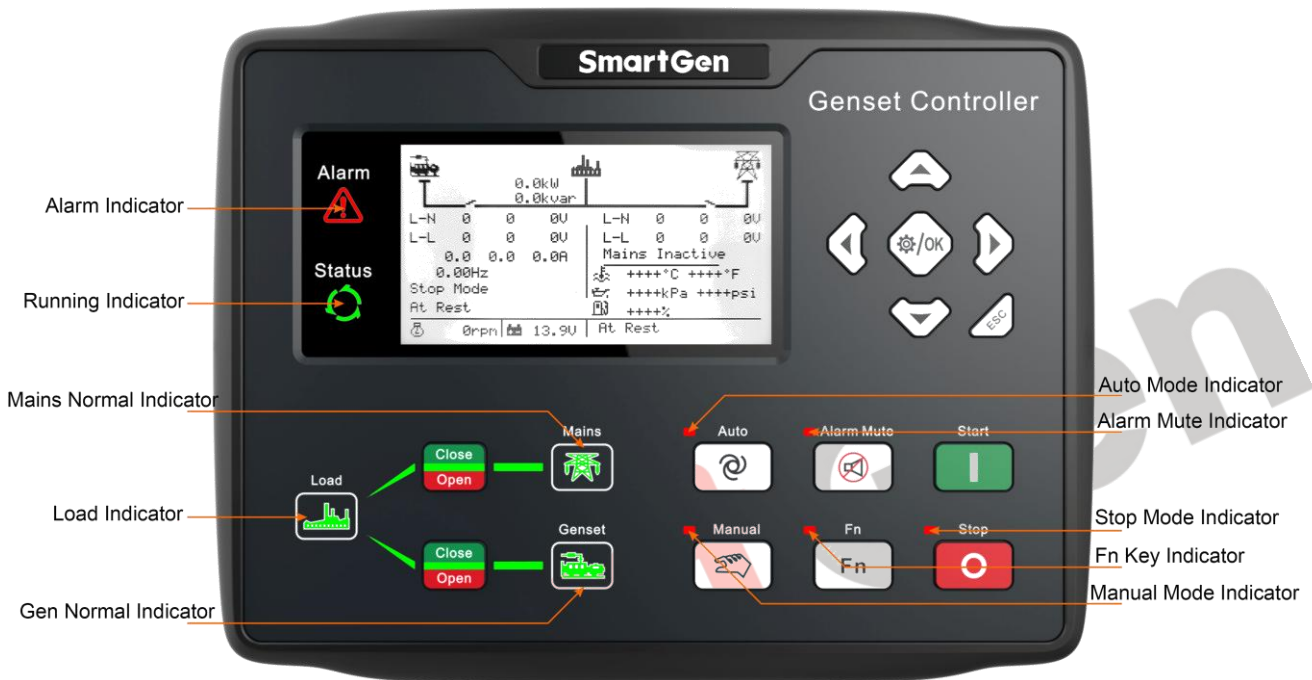

Fig.1 HGM9420N\_HGM9420LT Indication

**NOTE:** Description for parts of indicators:

Table 4 Alarm indicator Description

Alarm Type	Alarm Indicator
Warning	Slow flashing (1 time per second)
Block	Slow flashing (1 time per second)
Trip	Fast flashing (5 times per second)
Trip and Stop	Fast flashing (5 times per second)
Shutdown	Fast flashing (5 times per second)
No Alarm	Extinguished

**NOTE 1:** Running indicator: is normally illuminated after crank disconnection and before ETS stop and extinguished for other periods;

**NOTE 2:** Gen normal indicator: is normally illuminated when the generator is normal; flashing when generator state is abnormal; extinguished when there is no generating power.











**NOTE 3:** Mains normal indicator: is always illuminated when mains is normal, flashing when mains is abnormal, extinguished when there is no mains.

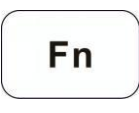
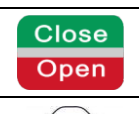

**NOTE 4:** Fn function key indicator: is illuminated when Fn function key is pressed, extinguished when group keys are pressed.

**NOTE 5:** When mains is disabled, mains normal indicator is extinguished, meanwhile mains close/open keys won't work.

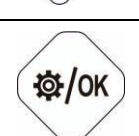
## 4.2 PUSHBUTTONS

**Table 5 Button Function Description**

Icons	Buttons	Description
	Stop Key	Stop the running generator in Auto/Manual mode; Reset alarm in stop mode; Press for over 3s, panel indicators can be tested (lamp test); During stop process, press this button again to stop the generator immediately.
	Start Key	Start the static genset in Manual mode.
	Manual Key	Press this key and the controller goes in Manual mode.
	Auto Key	Press this key and controller goes in Auto mode.
	Mute/ Reset Alarm Key	Remove the alarm sound; Remove the alarm by pressing for over 3s.
	Fn Key	Combine with other key to make shortcut setting; It can also be set to other function key (start key, stop key etc.);
	Close/Open Key	Close/open Gen or Mains breaker in manual mode.
	Up/Increase Key	1) Screen scroll; 2) Move up the cursor and increase value in setting menu.
	Down/Decrease Key	1) Screen scroll; 2) Move down the cursor and decrease value in setting menu.
	Left Key	1) Page scroll; 2) Left move the cursor in setting menu.
	Right Key	1) Page scroll; 2) Right move the cursor in setting menu.
	Set/Confirm Key	1) Enter setting screen; 2) Enter next menu in setting or confirm the settings.
	Exit Key	1) Return to main menu; 2) Return to previous menu in setting.





**NOTE:** Press  and  simultaneously in manual mode and it can force the generator to crank. At this time the controller shall not judge whether the genset start is successful or not according to the starting conditions. It is controlled by the operator. When operator observes that the engine has started, he/she should release the button and the start output will be deactivated. Safety on delay will be initiated.

**NOTE:** Regarding ECU genset, in Stop/Auto mode, Press  button and it shall power on the ECU (fuel output and ECU power output are active.).

**CAUTION:** Factory default password is “00318”, and users can change it in case others change the advanced parameter settings. Please clearly remember the password after changing. If you forget it, please contact SmartGen services and send the PD information in the controller page of “**ABOUT**” to the service personnel.

### 4.3 LCD DISPLAY

#### 4.3.1 MAIN DISPLAY

Paging is applied for the main screen;   is used for page scroll and   for screen scroll.

**Main Screen** includes the following contents:

Gen: voltage, frequency, current, active power, reactive power;

Mains: voltage, frequency;

Engine: speed, temperature, engine oil pressure, liquid level, battery voltage;

Part of status displays;

**Status** page includes the following contents:

SGE02-4G status, genset status, Mains breaker status, and breaker status;

**Engine** page includes the following contents:

Engine speed, engine temperature, engine oil pressure, fuel level, configurable analog 1, configurable analog 2, configurable analog 3, battery voltage, charger voltage, accumulated running time, accumulated start times, DC voltage;

**NOTE:** If CAN BUS is connected and engine information is from J1939, this page also includes: coolant pressure, coolant level, fuel temperature, fuel pressure, inlet temperature, exhaust temperature, turbo pressure, fuel consumption, total fuel consumption and so on. (Different engines have different parameters.)

**NOTE:** If AIN24 expansion module, or AIN16-M02 expansion module, or BAC150CAN expansion module is enabled, engine page also displays related monitoring data of expansion module.

**NOTE:** If oil tank volume and oil consumption setting are enabled, engine page also displays residue fuel, residue running time of fuel, and oil consumption parameters.

**Gen** page includes the following contents:

Line voltage, wire voltage, frequency, phase sequence, harmonic content, voltage unbalance percentage.

**Load** page includes the following contents:

Load current, active power of different phases, total active power and percentage, reactive power of different phases, total reactive power, apparent power of different phases, total apparent power, power factor of different phases, average power factor, accumulated electric power, earth current and percentage, unbalance current and percentage, average load of this run, historical max average load, average load of last run, accumulated electric power of this run.

**NOTE:** P stands for active power; Q stands for reactive power;

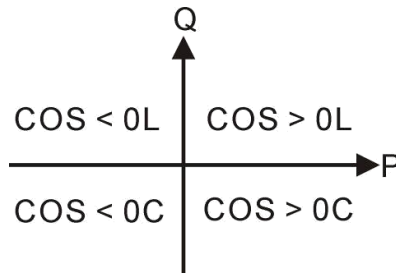
**Table 6 Power Factor Display Description**

Power Factor	Conditions	Active Power	Reactive Power	Remark
COS>0L	P>0,Q>0	Input	Input	Load is resistive induction.
COS>0C	P>0,Q<0	Input	Output	Load is resistive capacitance.
COS<0L	P<0,Q>0	Output	Input	Load equals an under excitation generator.
COS<0C	P<0,Q<0	Output	Output	Load equals an over excitation generator.

**▲NOTES:**

1. Input active power, and generator send active power to load.
2. Output active power, and load supply electricity to generator.
3. Input reactive power, and generator send reactive power to load.
4. Output reactive power, and load send reactive power to generator.

**Mains** page includes the following contents:

Phase voltage, wire voltage, frequency, phase sequence.

**Sync.** page includes the following contents:

**▲NOTE:** This displays when Sync. Transfer is enabled.

Voltage difference, frequency difference, phase position difference.

**Alarm** page:

**▲NOTE:** For ECU alarms and shutdown alarms, if the alarm information is displayed, check the engine according to it. Otherwise, please check the generator manual according to SPN alarm code.

**Event log** page:

Make records about all start/stop events (alarm events except warnings, manual start/stop events) and the real time when events occur;

**Maintenance Countdown** page includes the following contents:

3 maintenance countdowns display.

**▲NOTE:** if 3 maintenance countdowns are not enabled, they are not displayed.

**Others** page includes the following:

Module date and time, input and output status, communication indication, RS485 configuration, Ethernet configuration (if enabled), LCD temperature, MCU temperature.

**NOTE:** HGM9420N controller LCD temperature is +++°C.

**About** page includes the following contents:

Release software version, hardware version, and product PD number.



### 4.3.2 USER MENU AND PARAMETER SETTING

Press  key for more than 1s and it enters user menu.

- Parameter Setting

After inputting the correct password (factory default password is 00318) you can enter the parameter setting screen.

- Language

Optional Simplified Chinese, English and others.

- Commissioning

On load, off load and users-defined commissioning are optional. Defined commissioning can be configured regarding load on or load off, commissioning time, and which mode it shall return after commissioning (manual mode, auto mode and stop mode).

- U Flash Configurations Writing and Reading

Configuration files in U flash can be checked; loading configuration files, saving configuration files, saving new configuration files, configuration files can also be saved and loaded on PC; configuration file suffix name is .lgm.





- Clear users' accumulation

It can clear total running time A and B, total electric energy A and B.

Parameter settings include following contents:





- ✧ Module setting
- ✧ Mains setting
- ✧ Timers setting
- ✧ Engine setting
- ✧ Generator setting
- ✧ Load setting
- ✧ Switch setting
- ✧ Sensor setting
- ✧ Digital input setting
- ✧ Digital output setting
- ✧ Scheduled run setting
- ✧ Scheduled not run setting
- ✧ Maintenance setting
- ✧ Alt. Config setting
- ✧ Cycle start enable setting
- ✧ Sync. setting
- ✧ Expansion setting



For example:







Return	Start Delay	<p>Table 1:</p>   is used to change the contents needed to set;  is used to enter the setting (Table 2);  is used to exit from setting;
Module	Stop Delay	
Mains	Pre-heat Delay	
<b>Timers</b>	Fuel Delay	
Engine	Cranking Time	
Generator	Crank Rest Time	
Load	Safety On Time	



Switch	Start Idle Time	
Sensor	Warming Up Time	
Digital Input	Cooling Time	

Start Delay	00030s	Table 2:
<b>Stop Delay</b>		  is used to change the contents needed to
Pre-heat Delay		set;  is used to confirm the setting (Table 3),
Fuel Delay		 returns to previous menu (Table 1);
Cranking Time		
Crank Rest Time		
Safety On Time		
Start Idle Time		
Warming Up Time		
Cooling Time		

Start Delay	00030s	Table 3:
<b>Stop Delay</b>		 is used to enter the setting (Table 4),  is
Pre-heat Delay		used to return to previous menu (Table 2).
Fuel Delay		
Cranking Time		
Crank Rest Time		
Safety On Time		
Start Idle Time		
Warming Up Time		
Cooling Time		

Start Delay	00030s	Table 4:
<b>Stop Delay</b>		  is used to change cursor position; 
Pre-heat Delay		 is used to change the value where the cursor
Fuel Delay		is;  is used to confirm the setting (Table 3), 
Cranking Time		is used to exit the setting (Table 3).
Crank Rest Time		
Safety On Time		
Start Idle Time		
Warming Up Time		
Cooling Time		

**NOTE:** At configuration, press  and it can directly exit from the setting.

## 4.4 AUTO START/STOP OPERATION

### 4.4.1 ILLUSTRATION

Press  button and the indicator beside is illuminated, which means the genset is at Auto Start Mode.

### 4.4.2 AUTOMATIC START SEQUENCE

a) HGM9420N\_HGM9420LT start conditions:

**Mains enabled:** when mains is abnormal (over voltage, under voltage, over frequency, under frequency, loss of phase, reverse phase sequence), controller enters "Mains Abnormal Delay", LCD mains status line displays countdown. When mains abnormal delay is over, it enters "Start Delay"; or when remote start (on load) input is active, it enters "Start Delay".

**Mains disabled or Mains only displayed:** when remote start (onload) input is active, it enters "Start Delay".

- b) "Start Delay" countdown will be displayed on genset status line;
- c) When start delay is over, preheating relay is energized (if configured), 'preheat delay XX s' information will be displayed on status line;
- d) After the above delay, the fuel relay is energized, and then the start relay is engaged. During the 'start time', if the genset does not start, then fuel relay and start relay stops outputting, and enter 'crank rest time', waiting for next crank;
- e) Should the start continues beyond the set attempts, the controller issues 'start failure' and stops the genset and at the same time alarm page on LCD displays 'start failure alarm';
- f) If it starts during the attempts, it enters 'safety on time', and during this period Low Oil Pressure, High Temperature, Under speed and Charge Alternator Failure alarms are all inactive; After 'safety on time', it enters 'start idle delay' (if configured);
- g) During 'start idle delay', under speed, under frequency, under voltage alarms are inhibited. When this delay is over, 'warming up delay' is initiated (if configured);
- h) When synchronous transfer is disabled, mains abnormal start or remote start (onload) input is active, and when warming up delay is over, if gen is normal, gen status indicator is illuminated; if gens voltage, frequency meet the onload requirements, gen close relay outputs and genset takes the load. Gen supply indicator is illuminated, and genset enters normal running status; if genset voltage or frequency is not normal, controller issues alarm and shutdowns (LCD alarm page displays gen alarm type);
- i) When synchronous transfer is enabled, mains is normal and remote start (onload) input is active, when warming up delay is over, if gen is normal, then gen status indicator is illuminated. Controller issues close signal after waiting for genset and mains meeting the sync. requirement; after controller detects gen close feedback, it immediately issues mains open signal, and genset takes the load.
- j) When synchronous transfer is enabled, mains abnormal start, and warming up delay is over, if gen is normal, gen status indicator is illuminated; if genset voltage, frequency is up to the load requirement, then gen close relay outputs, and genset takes the load. Gen supply indicator is illuminated and genset enters normal running status.



**▲NOTE:** When Remote Start is applied to start (Off Load), the procedure is the same as above. Only when it is in

procedure h) or i), generator close relay is deactivated, and moreover, genset is off load.

#### 4.4.3 AUTOMATIC STOP SEQUENCE

- a) In the process of genset normal running, if Mains recovers, genset enters "Mains Voltage Normal Delay". When Mains normal is confirmed, Mains status indicator is illuminated and "Stop Delay" is initiated. Or when remote start input is inactive, "Stop Delay" is initiated;
- b) After stop delay is over:
  - 1) Synchronous Transfer Disabled: Cooling Time is initiated, and at the same time gen close relay is disconnected; after "switch transfer delay", Mains close relay outputs and Mains takes the load; Gen supply indicator is extinguished and Mains supply indicator is illuminated;
  - 2) Synchronous Transfer Enabled: Controller issues Mains close signal after waiting for genset and Mains meeting sync. requirement; when Mains close feedback signal is detected, it immediately issues Gen open signal; Gen supply indicator is extinguished, and Mains takes the load; Mains supply indicator is illuminated and Cooling Time is initiated;
- c) At entering "stop idle delay" (if configured), the idling speed relay is energized;
- d) "ETS solenoid hold" begins, ETS relay is energized while fuel relay is de-energized, and complete stop is detected automatically;
- e) "Fail to stop delay" begins, and complete stop is detected automatically;
- f) When generator is stopped completely, "after stop delay" will be initiated. Otherwise, controller enters "fail to stop" period, and issues failed to stop alarm (If generator stops successfully after 'fail to stop' alarm has initiated, "after stop delay" will be initiated and the alarm will automatically be removed.);
- g) Generator is placed into its standby mode after its 'after stop delay';

#### 4.5 MANUAL START/STOP OPERATION





- a) HGM9420N\_HGM9420LT: Manual mode is selected by pressing the  button; a LED besides the button will be illuminated to confirm the operation; then press  button to start the gen-set; it can detect crank disconnect condition and generator accelerates to high-speed running automatically. With high temperature, low oil pressure, over speed and abnormal voltage during generator running, controller can protect genset to stop quickly (please refer to c-i of **4.3.2 Automatic Start Sequence** for detailed procedures).
- b) MANUAL STOP: Press  and it can shut down the running generators. (Please refer to b-g of **4.3.3 Automatic Start Sequence** for detailed procedures).



## 5 CONTROLLER SWITCH CONTROL PROCEDURES

### 5.1 SWITCH CONTROL PROCEDURE FOR SYNC TRANSFER DISABLED



#### 5.1.1 MANUAL TRANSFER PROCESS

When controller is in **Manual** mode, the switch control procedures will start through manual transfer procedures. Users can control the loading transfer of ATS via pressing switch close/open keys.

**Mains Enabled:** If open detection is disabled, press gen close/open key  ; if gen takes the load, then switch open outputs; if load is disconnected, then gen closes; if Mains takes the load, then mains opens; when open delay is over, gen closes. Press mains close/open key  ; if mains takes the load, then switch open outputs; if load is disconnected, then Mains closes; if Gen takes the load, then gen opens; when open delay is over, Mains closes.

If open detection is enabled and Mains taking load transfers to Gen taking load, first press Mains open key  , after open delay press Gen close key, and Gen closes (directly press Gen close key, no action). If Gen loading transfers to Mains loading, the same procedure as above;

**Mains Disabled:** Press Gen close/open key  , if Gen isn't taking the load, then Gen close outputs.

Press Gen close/open key  , if Gen takes the load, then Gen open outputs.

#### 5.1.2 AUTOMATIC TRANSFER PROCEDURE

When controller is in Auto or Stop mode, the switch control procedure is automatic control procedure.

a) If input configuration is close status auxiliary input,

##### **Mains Enabled:**

- If open detection is enabled and Mains loading transfers to Gen loading, after open delay and transfer interval delay, failed to transfer starts to detect at the same time of open output. Detection time is due. if it fails to open, then Gen won't close; otherwise Gen closes. At the same time of Gen close, failed to transfer starts to detect; detection time is due; if it fails to close, then wait for gen close. If failed to transfer warning is enabled, close/open failure will issue warning signal. About Gen loading transferring to Mains loading, the same is as above.
- If open detection is disabled and Mains loading transfers to Gen loading, after open delay and transfer interval delay, Gen closes. At the same time of gen close, failed to transfer starts to detect. detection time is due; if it fails to close, then wait for gen close; if failed to transfer warning is enabled, warning signal will be issued. About Gen loading transferring to Mains loading, the same is as above.

##### **Mains Disabled**

- When breaker open detection is enabled, gen on-load changes to generator off-load. After open delay in the process of open output, transfer failure is detected. When the detection time is due, if open fails, then open is waited for, otherwise open is completed. For generator off-load changing to

generator on-load, after close delay, in the process of close output, transfer failure is detected. When the detection time is due, if close fails, then close is waited for, otherwise close is completed.

- If transfer failure warning is enabled, then open/close failures shall issue warning signals.
  - When breaker open detection is disabled, generator on-load changes to generator off-load. After open delay, open is completed. For generator off-load changing to generator on-load, after close delay, in the process of close output, transfer failure is detected. When the detection time is due, if close fails, then close is waited for, otherwise close is completed. If transfer failure warning is enabled, then close failure shall issue warning signal.
- b) In case input port is not configured as close status auxiliary input,

**Mains Enabled:**

For mains on-load changing to generator on-load, after open delay and transfer rest delay, generator close occurs. For generator on-load changing to mains on-load, it is the same as above.

**Mains Disabled:**

For generator off-load changing to generator on-load, generator close outputs. For generator on-load changing to generator off-load, generator open outputs.

**NOTE 1:** In case of applying ATS without neutral breaking, open detection shall be disabled.

**NOTE 2:** In case of applying ATS with neutral breaking, open detection can be enabled and disabled. If it is enabled, please configure open output.

**NOTE 3:** In case of applying AC contactor, open detection is recommended to be enabled.

**5.2 SWITCH CONTROL PROCEDURE FOR SYNCHRONOUS TRANSFER ENABLED**

**5.2.1 MANUAL TRANSFER PROCEDURE**



Breaker is switched by manual control if controller is in manual mode.

Operator controls ATS load transfer via C/O button.

**Mains Enabled:**

Press Gen close/open key   :



1. In case of generator on-load, then generator open outputs;
2. In case of generator&mains off-load, then generator close occurs;
3. In case of mains on-load, when generator synchronization close is over, mains open occurs and generator is on-load.

**NOTE:** In the process of waiting for synchronization or if synchronization fails, press mains C/O key   to cancel synchronization, and mains breaker is open. Then press gen C/O button to force gen on-load.



Press Mains Close/Open key   :

1. In case of gen on-load, then mains open outputs;
2. In case of mains/gen both off-load, then mains close occurs;

3. In case of gen on-load, then mains synchronization close is over, gen open occurs and mains is on-load.

**NOTE:** In the process of waiting for synchronization or if synchronization fails, press generator C/O button   to cancel synchronization, and generator breaker is open. Then press mains C/O button to force mains on-load.

#### **Mains Disabled:**

Press Gen C/O key  , and if generator is off-load, then generator close outputs; if generator is on-load, then generator open outputs.

### **5.2.2 AUTO SWITCHING PROCESS**

Breaker is switched by automatic control if controller in auto or stop mode.

#### **Mains Enabled:**

1. For mains on-load changing to generator on-load,

Controller shall output generator close when genset and mains meet synchronization conditions. When it detects generator close feedback signal, mains open outputs and generator is on-load. If generator close is outputted, generator close feedback signal is not detected during the C/O synchronization period, generator open is outputted and mains is on-load. Mains open status is detected at the time of mains open output. When the C/O synchronization time is due, if mains open fails, generator open outputs. If synchronization signal is not detected during the set synchronization failure time, then synchronization failure alarm is issued. If synchronization failure alarm is warning and transfer is forced to be enabled after synchronization failure ten mains open outputs. After open delay, mains open status is detected at the time of mains open output. When detection time is due, if mains open fails, then generator shall not close, otherwise, after transfer delay generator close outputs. Generator close status is detected at the time of generator close output. When the detection time is due, if generator close fails generator close is waited for. Transfer procedure is as below:



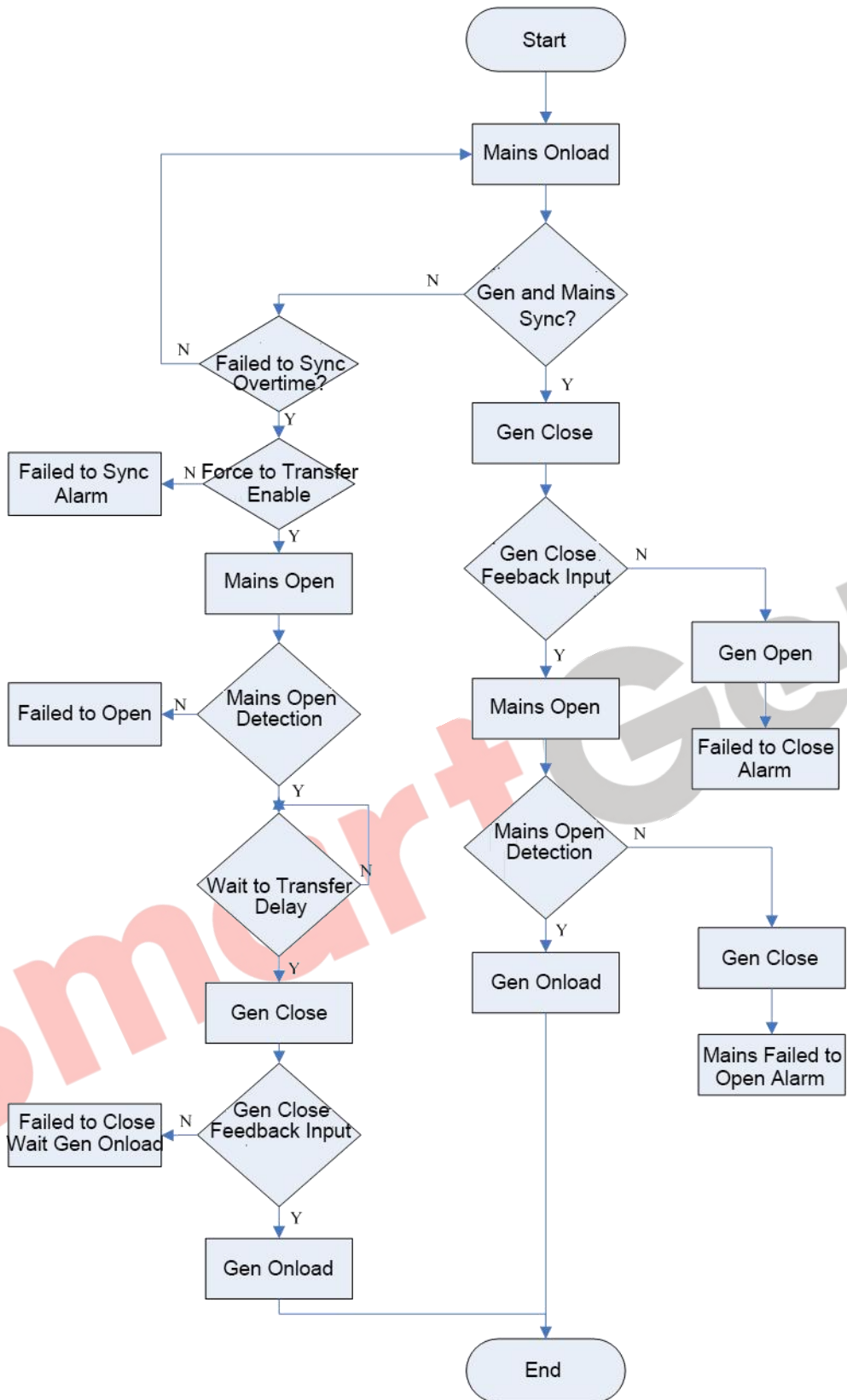

**Fig. 2 Mains Onload Transferring to Gen Onload**

2. For gen on-load changing to mains on-load,

Controller shall output mains close when genset and mains meet synchronization conditions. When it detects mains close feedback signal, generator open outputs and mains is on-load. If mains close is outputted, mains close feedback signal is not detected during the C/O synchronization period, mains



open is outputted and generator is on-load. Generator open status is detected at the time of generator open output. When the C/O synchronization time is due, if generator open fails, mains open outputs. If synchronization signal is not detected during the set synchronization failure time, then synchronization failure alarm is issued. If synchronization failure alarm is warning and transfer is forced to be enabled after synchronization failure, then generator open outputs. After open delay, generator open status is detected at the time of generator open output. When detection time is due, if generator open fails, then mains shall not close, otherwise, after transfer delay mains close outputs. Mains close status is detected at the time of mains close output. When the detection time is due, if mains close fails mains close is waited for. Transfer procedure is as below:

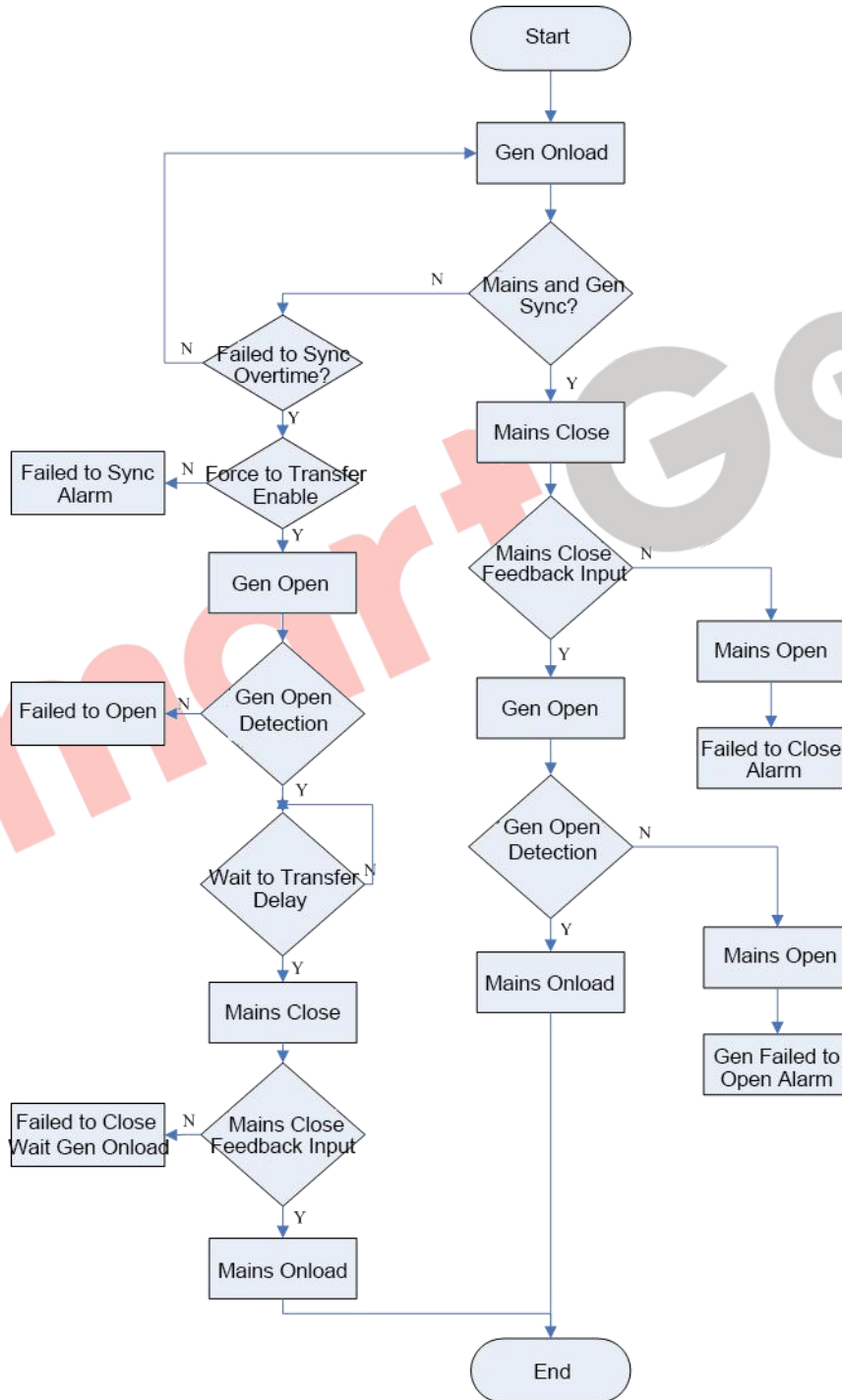

**Fig. 3 Gen Onload Transferring to Mains Onload**

### Mains Disabled:

For generator off-load changing to generator on-load, generator close outputs. For generator on-load changing to generator off-load, generator open outputs.

**NOTE 1:** Mains close status and Generator close status are needed to be configured for input port, otherwise controller shall issue mains breaker failure warning or generator breaker failure warning.

**NOTE 2:** For synchronization failure alarm, it is needed to press  longer to remove the alarm.

**NOTE 3:** If synchronization C/O detection time is less than breaker C/O time, then synchronization C/O detection time is breaker C/O time.

## 6 PROTECTIONS

### 6.1 WARNING ALARMS

When controller detects the warning alarm, it only issues warning, and the genset does not open and shutdown. When the warning signal disappears, alarm reset automatically.

**Table 7 Warning Alarms**

No	Type	Description
1	Over Speed	When this is enabled, and the controller detects that the engine speed is above the pre-set limit, it will initiate a warning. It is always detected.
2	Under Speed	When this is enabled and the controller detects that the engine speed is below the pre-set limit, it will initiate a warning. It is detected after 'warming up' and before 'stop idle'.
3	Loss of Speed Signal	When the controller detects the engine speed is 0, it shall issue a warning. It is detected after 'safety on time' before 'ETS solenoid hold'.
4	Gen Over Frequency	When this is enabled, and the controller detects the frequency is above the preset limit, it shall issue a warning. It is detected always.
5	Gen Under Frequency	When this is enabled, and the controller detects the frequency is below the preset limit, it shall issue a warning. It is detected after 'warming up time' before 'stop idle time'.
6	Gen Over Voltage	When this is enabled, and the controller detects the voltage is above the preset limit, it shall issue a warning. It is always detected.
7	Gen Under Voltage	When this is enabled, and the controller detects the voltage is below the preset limit, it shall issue a warning. It is detected after 'warming up time' before 'stop idle time'.
8	Gen Over Current	When this is enabled, and the controller detects the current is above the preset limit, it shall issue a warning. It is always detected.
9	Negative Sequence	When this is enabled, and the controller detects the value is above the



No	Type	Description
	Current	preset limit, it shall issue a warning. It is always detected.
10	Earth Fault	When this is enabled, and the controller detects the earth current is above the preset limit, it shall issue a warning. It is always detected.
11	Reverse Power	When this is enabled, and the controller detects the reverse power (negative) is above the preset limit, it shall issue a warning. It is always detected.
12	Over Power	When this is enabled, and the controller detects the genset power (positive) is above the preset limit, it shall issue a warning. It is always detected.
13	Loss Excitation	When this is enabled, and the controller detects the genset reactive power (negative) is above the preset limit, it shall issue a warning. It is always detected.
14	ECU Alarm	When the controller receives the engine alarm signal from J1939, it shall issue a warning. It is always detected.
15	Temp. Sensor Open	When the controller detects the sensor circuit is open, it shall issue a warning. It is always detected.
16	Engine Temp High	When this is enabled, and the controller detects the temp. is above the preset limit, it shall issue a warning. It is detected after 'safety on time' before 'ETS solenoid hold'.
17	Engine Temp Low	When this is enabled, and the controller detects the temp. is below the preset limit, it shall issue a warning. It is detected after 'safety on time' before 'ETS solenoid hold'.
18	Oil Pressure Sensor Open	When the controller detects the sensor circuit is open, it shall issue a warning. It is always detected.
19	Oil Pressure Low	When this is enabled, and the controller detects the pressure is below the preset limit, it shall issue a warning. It is detected after 'safety on time' before 'ETS solenoid hold'.
20	Oil Pressure Sensor Wrong	When voltage or current input is selected for the curve type of the controller, and the controller detects input signal is abnormal, it shall issue a warning, and meanwhile the curve is transferred to resistor type to prevent damaging the controller. It is detected always.
21	Fuel Level Sensor Open	When the controller detects the sensor circuit is open, it shall issue a warning. It is always detected.
22	Fuel Level Low	When this is enabled, and the controller detects the level is below the preset limit, it shall issue a warning. It is always detected.



No	Type	Description
23	Fuel Level Sensor Wrong	When controller curve type selects voltage or current input, and when controller detects input signal abnormal, it will issue a warning signal; meanwhile curve type will transfer to resistance to prevent damaging the controller. It is always detected.
24	Flex. Sensor 1 Open	When controller detects sensor is open, it will issue a warning signal; It is always detected.
25	Flex. Sensor 1 High	When over high warning is enabled, and the controller detects the sensor value is above the preset upper limit, it shall issue a warning. It is detected after 'safety on time' before 'ETS solenoid hold' when the sensor is selected as temperature sensor and pressure sensor; It is always detected when the sensor is selected as fuel level sensor.
26	Flex. Sensor 1 Low	When over low warning is enabled, and the controller detects the sensor value is below the preset low limit, it shall issue a warning. It is detected after 'safety on time' before 'ETS solenoid hold' when the sensor is selected as temperature sensor and pressure sensor; It is always detected when the sensor is selected as fuel level sensor.
27	Flex. Sensor 1 Wrong	When voltage or current input is selected for the curve type of the controller, and the controller detects input signal is abnormal, it shall issue a warning, and meanwhile the curve is transferred to resistor type to prevent damaging the controller. It is detected always.
28	Flex. Sensor 2 Open	When the controller detects the sensor circuit is open, it shall issue a warning. It is always detected.
29	Flex. Sensor 2 High	When over high warning is enabled, and the controller detects the sensor value is above the preset upper limit, it shall issue a warning. It is detected after 'safety on time' before 'ETS solenoid hold' when the sensor is selected as temperature sensor and pressure sensor; It is always detected when the sensor is selected as fuel level sensor.
30	Flex. Sensor 2 Low	When over low warning is enabled, and the controller detects the sensor value is below the preset low limit, it shall issue a warning. It is detected after 'safety on time' before 'ETS solenoid hold' when the sensor is selected as temperature sensor and pressure sensor; It is always detected when the sensor is selected as fuel level sensor.
31	Flex. Sensor 2 Wrong	When voltage or current input is selected for the curve type of the controller, and the controller detects input signal is abnormal, it shall issue a warning, and meanwhile the curve is transferred to resistor type to prevent damaging the controller. It is detected always.
32	Flex. Sensor 3 Open	When the controller detects the sensor circuit is open, it shall issue a warning. It is always detected.



No	Type	Description
33	Flex. Sensor 3 High	When over high warning is enabled, and the controller detects the sensor value is above the preset upper limit, it shall issue a warning. It is detected after 'safety on time' before 'ETS solenoid hold' when the sensor is selected as temperature sensor and pressure sensor; It is always detected when the sensor is selected as fuel level sensor.
34	Flex. Sensor 3 Low	When over low warning is enabled, and the controller detects the sensor value is below the preset low limit, it shall issue a warning. It is detected after 'safety on time' before 'ETS solenoid hold' when the sensor is selected as temperature sensor and pressure sensor; It is always detected when the sensor is selected as fuel level sensor.
35	Fail to Stop	After 'fail to stop delay' is over, if the genset does not stop completely, it will initiate a warning alarm.
36	Charge Alternator Failure	When this is enabled and the controller detects that charger voltage is below the pre-set limit, it will initiate a warning alarm. It is detected when the genset is normally running.
37	Battery Over Volt	When this is enabled, and the controller detects the battery voltage is above the preset limit, it shall issue a warning signal. It is always detected.
38	Battery Under Volt	When this is enabled, and the controller detects the battery voltage is below the preset limit, it shall issue a warning signal. It is always detected.
39	Fail to Sync.	If the controller doesn't detect sync. signal within the pre-set time, it will initiate a warning alarm. It is detected when GCB closes.
40	Gen Breaker Alarm	When Sync. transfer is enabled, and when gen close status input is not set for controller input port, the controller will initiate a warning alarm. It is always detected.
41	Mains Breaker Alarm	When Sync. transfer is enabled, and when mains close status input is not set for controller input port, the controller will initiate a warning alarm. It is always detected.
42	Maintenance Time 1 Due	Maintenance 1 enabled, when maintenance 1 countdown is equal to maintenance 1 countdown A or maintenance 1 countdown B, or maintenance 1 countdown is 0, controller will issue a warning signal. It is detected when genset is running.
43	Maintenance Time 2 Due	Maintenance 2 enabled, when maintenance 2 countdown is equal to maintenance 2 countdown A or maintenance 2 countdown B, or maintenance 2 countdown is 0, controller will issue a warning signal; It is detected when genset is running.
44	Maintenance Time 3 Due	Maintenance 3 enabled, when maintenance 3 countdown is equal to maintenance 3 countdown A or maintenance 3 countdown B, or maintenance 3 countdown is 0, controller will issue a warning signal; It is detected when genset is running.





No	Type	Description
45	Gen Reverse Phase	When controller detects gen reverse phase sequence, controller issues a warning signal. Gen reverse phase sequence detection enabled, it is detected when 3Ph 4W or 2Ph 3W phase voltage is over 30V, 3Ph 3W line voltage is over 50V.
46	Gen Loss of Phase	When controller detects gen loss of phase, controller issues a warning signal; Gen loss of phase enabled, it is detected when 3Ph 4W or 2Ph 3W phase voltage is above 30V, or 3Ph 3W line voltage is above 50V.
47	Switch Fail	When controller detects switch close/open failure and switch failure warning is enabled, controller issues a warning signal.
48	Digital Input Alarm	When digital input port is selected to user defined and it is active, controller issues related input alarm signal; It is detected in the detection range of input port settings.
49	PLC Function Alarm	When PLC function selects user defined and it is active, controller issues related PLC function alarm signal. It is detected in the detection range of PLC function settings.
50	DIN16 Com. Fail	When DIN16 communication is enabled and the controller cannot receive the communication data, it will initiate a warning. It is always detected.
51	DIN16 Input Alarm	When DIN16 input is set users-defined and if it is active, the controller will initiate a warning. It is detected in the detection range set in the input.
52	DOUT16 Com. Fail	When DOUT16 communication is enabled and the controller cannot receive the communication data, it will initiate a warning. It is always detected.
53	AIN24 Com. Fail	When AIN24 communication is enabled and the controller cannot receive the communication data of AIN24, it will initiate a warning. It is always detected.
54	AIN24 Cylinder Temp. High	When this is enabled and the controller detects cylinder temperature has exceeded the pre-set value, it will initiate a warning alarm. It is detected after 'safety on time' before 'ETS solenoid hold'.
55	AIN24 Exhaust Temp. High	When this is enabled and the controller detects exhaust temperature has exceeded the pre-set value, it will initiate a warning alarm. It is detected after 'safety on time' before 'ETS solenoid hold'.
56	AIN24 Cylinder Temp. Difference High	When this is enabled and the controller detects cylinder temp. difference has exceeded the pre-set value, it will initiate a warning alarm. It is detected after 'safety on time' before 'ETS solenoid hold'.
57	AIN24 Sensor Open	When the controller detects the sensor circuit is open, it shall issue a warning. It is always detected.
58	AIN24 Sensor High	When over high warning is enabled, and the controller detects the sensor value is above the preset upper limit, it shall issue a warning.



No	Type	Description
		It is detected after 'safety on time' before 'ETS solenoid hold' when the sensor is selected as temperature sensor and pressure sensor; It is always detected when the sensor is selected as fuel level sensor.
59	AIN24 Sensor Low	When over low warning is enabled, and the controller detects the sensor value is below the preset lower limit, it shall issue a warning. It is detected after 'safety on time' before 'ETS solenoid hold' when the sensor is selected as temperature sensor and pressure sensor; It is always detected when the sensor is selected as fuel level sensor.
60	Power Factor Low	When this is enabled and the controller detects that the generator power factor has fallen below the pre-set value, it will initiate a warning alarm. It is always detected.
61	THD High	When this is enabled and the controller detects that the THD has exceeded the pre-set value, it will initiate a warning alarm. It is always detected.
62	Gen Volt Unbalance	When this is enabled and the controller detects that the voltage unbalanced value has exceeded the pre-set value, it will initiate a warning alarm. It is always detected.
63	Cycle Com Fail	Cycle Start Enable is enabled, when controller cannot receive the communication data of another controller, controller issues alarm signal. It is detected when controller is in auto mode.
64	SGE02-4G Com Fail	When SGE02 (4G wireless communication expansion card) is enabled, and GSM module is not detected, controller issues a warning signal; It is detected always.
65	AIN16-M02 Com Fail	When AIN16-M02 is enabled, and when controller cannot receive the communication data of AIN16-M02 module, controller issues a warning signal; It is detected always.
66	AIN16-M02 Sensor Open	When controller detects sensor is open, controller issues an alarm signal; It is detected always.
67	AIN16-M02 Sensor High	When over high warning is enabled, and the controller detects the sensor value is above the preset upper limit, it shall issue a warning. It is detected after 'safety on time' before 'ETS solenoid hold' when the sensor is selected as temperature sensor and pressure sensor; It is always detected when the sensor is selected as fuel level sensor.
68	AIN16-M02 Sensor Low	When over low warning is enabled, and the controller detects the sensor value is below the preset lower limit, it shall issue a warning. It is detected after 'safety on time' before 'ETS solenoid hold' when the sensor is selected as temperature sensor and pressure sensor; It is always detected when the sensor is selected as fuel level sensor.
69	AIN8 Com Fail	AIN8 enabled; when controller cannot receive AIN8 module communication data, it will issue alarm signal;





No	Type	Description
		It is detected always.
70	AIN8 Sensor Open	When controller detects sensor open, it issues alarm signal; It is detected always.
71	AIN8 Sensor High	Enabled; when the sensor value detected by the controller is over the pre-set upper limit, controller issues alarm signal; When sensor type selects temp sensor and pressure sensor, it is detected after safety on run before ETS stop; It is detected always when sensor type selects liquid level sensor.
72	AIN8 Sensor Low	Enabled; when the sensor value detected by the controller is below the pre-set lower limit, controller issues alarm signal; When sensor type selects temp sensor and pressure sensor, it is detected after safety on run before ETS stop; It is detected always when sensor type selects liquid level sensor.
73	BAC150CAN Com Fail	When BAC150CAN is enabled, and when controller cannot receive communication data of BAC150CAN module, controller issues a warning signal; It is always detected.

## 6.2 BLOCK ALARMS

When the controller detects block signals, it only issues warning and the genset does not shutdown and not open. Users need to reset alarms manually.

**Table 8 Block Alarms**

No	Type	Description
1	Over Speed	When this is enabled, and the controller detects that the genset speed is above the pre-set limit, it will initiate a block alarm. It is always detected.
2	Under Speed	When this is enabled and the controller detects that the genset speed is below the pre-set limit, it will initiate a block alarm. It is detected after 'warming up' and before 'stop idle'.
3	Loss of Speed Signal	When the controller detects the genset speed is 0, it shall issue a block alarm. It is detected after 'safety on time' and before 'ETS solenoid hold'.
4	Gen Over Frequency	When this is enabled, and the controller detects the genset frequency is above preset limit, it shall issue a block alarm. It is detected always.
5	Gen Under Frequency	When this is enabled, and the controller detects the frequency is below the preset limit, it shall issue a block alarm. It is detected after 'warming up' and before 'stop idle'.
6	Gen Over Voltage	When this is enabled, and the controller detects the genset voltage is above preset limit, it shall issue a block alarm. It is detected always.
7	Gen Under Voltage	When this is enabled, and the controller detects the voltage is below the preset limit, it shall issue a block alarm. It is detected after 'warming up' and before 'stop idle'.
8	Gen Over Current	When this is enabled, and the controller detects the genset current is above preset limit, it shall issue a block alarm. It is detected always.
9	Negative Sequence Current	When this is enabled, and the controller detects the unbalanced current is above preset limit, it shall issue a block alarm. It is detected always.
10	Earth Fault	When this is enabled, and the controller detects the earth current is above the preset limit, it shall issue a block alarm. It is always detected.
11	Reverse Power	When this is enabled, and the controller detects the reverse power (negative) is above the preset limit, it shall issue a block alarm. It is always detected.
12	Over Power	When this is enabled, and the controller detects the genset power (positive) is above the preset limit, it shall issue a block alarm. It is always detected.
13	Loss Excitation	When this is enabled, and the controller detects the genset reactive



No	Type	Description
		power (negative) is above the preset limit, it shall issue a block alarm. It is always detected.
14	ECU Alarm	When the controller receives the engine alarm signal from J1939, it shall issue a block alarm. It is always detected.
15	Temp. Sensor Open	When the controller detects the sensor circuit is open, it shall issue a block alarm. It is always detected.
16	Engine Temp High	When this is enabled, and the controller detects the temp. is above the preset limit, it shall issue a block alarm. It is detected after 'safety on time' before 'ETS solenoid hold'.
17	Engine Temp Low	When this is enabled, and the controller detects the temp. is below the preset limit, it shall issue a block alarm. It is detected after 'safety on time' before 'ETS solenoid hold'.
18	Oil Pressure Sensor Open	When the controller detects the sensor circuit is open, it shall issue a block alarm. It is always detected.
19	Oil Pressure Low	When this is enabled, and the controller detects the pressure is below the preset limit, it shall issue a block alarm. It is detected after 'safety on time' before 'ETS solenoid hold'.
20	Oil Pressure Sensor Wrong	When voltage or current input is selected for the curve type of the controller, and the controller detects input signal is abnormal, it shall issue a block alarm, and meanwhile the curve is transferred to resistor type to prevent damaging the controller. It is detected always.
21	Fuel Level Sensor Open	When the controller detects the sensor circuit is open, it shall issue a block alarm. It is always detected.
22	Fuel Level Low	When this is enabled, and the controller detects the level is below the preset limit, it shall issue a block alarm. It is always detected.
23	Fuel Level Sensor Wrong	When voltage or current input is selected for the curve type of the controller, and the controller detects input signal is abnormal, it shall issue a block alarm, and meanwhile the curve is transferred to resistor type to prevent damaging the controller. It is detected always.
24	Flex. Sensor 1 Open	When the controller detects the sensor circuit is open, it shall issue a block alarm. It is always detected.
25	Flex. Sensor 1 High	When over high block alarm is enabled, and the controller detects the sensor value is above the preset upper limit, it shall issue a block alarm. It is detected after 'safety on time' before 'ETS solenoid hold' when the sensor is selected as temperature sensor and pressure sensor;



No	Type	Description
		It is always detected when the sensor is selected as fuel level sensor.
26	Flex. Sensor 1 Low	When over low block alarm is enabled, and the controller detects the sensor value is below the preset low limit, it shall issue a block alarm. It is detected after 'safety on time' before 'ETS solenoid hold' when the sensor is selected as temperature sensor and pressure sensor; It is always detected when the sensor is selected as fuel level sensor.
27	Flex. Sensor 1 Wrong	When voltage or current input is selected for the curve type of the controller, and the controller detects input signal is abnormal, it shall issue a block alarm, and meanwhile the curve is transferred to resistor type to prevent damaging the controller. It is detected always.
28	Flex. Sensor 2 Open	When the controller detects the sensor circuit is open, it shall issue a block alarm. It is always detected.
29	Flex. Sensor 2 High	When over high block alarm is enabled, and the controller detects the sensor value is above the preset upper limit, it shall issue a block alarm. It is detected after 'safety on time' before 'ETS solenoid hold' when the sensor is selected as temperature sensor and pressure sensor; It is always detected when the sensor is selected as fuel level sensor.
30	Flex. Sensor 2 Low	When over low block alarm is enabled, and the controller detects the sensor value is below the preset low limit, it shall issue a block alarm. It is detected after 'safety on time' before 'ETS solenoid hold' when the sensor is selected as temperature sensor and pressure sensor; It is always detected when the sensor is selected as fuel level sensor.
31	Flex. Sensor 2 Wrong	When voltage or current input is selected for the curve type of the controller, and the controller detects input signal is abnormal, it shall issue a block alarm, and meanwhile the curve is transferred to resistor type to prevent damaging the controller. It is detected always.
32	Flex. Sensor 3 Open	When the controller detects the sensor circuit is open, it shall issue a block alarm. It is always detected.
33	Flex. Sensor 3 High	When over high block alarm is enabled, and the controller detects the sensor value is above the preset upper limit, it shall issue a block alarm. It is detected after 'safety on time' before 'ETS solenoid hold' when the sensor is selected as temperature sensor and pressure sensor; It is always detected when the sensor is selected as fuel level sensor.
34	Flex. Sensor 3 Low	When over low block alarm is enabled, and the controller detects the sensor value is below the preset low limit, it shall issue a block alarm. It is detected after 'safety on time' before 'ETS solenoid hold' when the sensor is selected as temperature sensor and pressure sensor; It is always detected when the sensor is selected as fuel level sensor.
35	Failed to Stop	After 'fail to stop delay' is over, if the genset does not stop completely, it



No	Type	Description
		will initiate a block alarm.
36	Charge Alternator Failure	When this is enabled, and the controller detects the charger voltage value is below the preset limit, it shall issue a block alarm. It is detected when the genset is normally running.
37	Battery Over Volt	When this is enabled, and the controller detects the battery voltage is above the preset limit, it shall issue a block signal. It is always detected.
38	Battery Under Volt	When this is enabled, and the controller detects the battery voltage is below the preset limit, it shall issue a block signal. It is always detected.
39	Maintenance Time 1 Due	Maintenance 1 enabled, when maintenance 1 countdown is equal to maintenance 1 countdown A or maintenance 1 countdown B, or maintenance 1 countdown is 0, controller will issue a block signal. It is detected when genset is running.
40	Maintenance Time 2 Due	Maintenance 2 enabled, when maintenance 2 countdown is equal to maintenance 2 countdown A or maintenance 2 countdown B, or maintenance 2 countdown is 0, controller will issue a block signal; It is detected when genset is running.
41	Maintenance Time 3 Due	Maintenance 3 enabled, when maintenance 3 countdown is equal to maintenance 3 countdown A or maintenance 3 countdown B, or maintenance 3 countdown is 0, controller will issue a block signal; It is detected when genset is running.
42	Digital Input Alarm	When the digital input port is set users-defined and if it is active, the controller will initiate a block signal for the input port. It is detected in the detection range set for the input port.
43	PLC Functions Alarm	When PLC function is set users-defined and if it is active, the controller will initiate a block signal. It is detected in the detection range set by the PLC function.
44	DIN16 Com. Fail	When DIN16 communication is enabled and the controller cannot receive the communication data of DIN16, it will initiate a block signal. It is always detected.
45	DIN16 Input Alarm	When DIN16 input is set users-defined and if it is active, the controller will initiate a block signal. It is detected in the detection range set in the input.
46	DOUT16 Com. Fail	When DOUT16 communication is enabled and the controller cannot receive the communication data of DOUT16, it will initiate a block signal. It is always detected.
47	AIN24 Com. Fail	When AIN24 communication is enabled and the controller cannot receive the communication data, it will initiate a block signal. It is always detected.
48	AIN24 Cylinder Temp. High	When this is enabled and the controller detects cylinder temperature has exceeded the pre-set value, it will initiate a block alarm. It is detected after 'safety on time' before 'ETS solenoid hold'.



No	Type	Description
49	AIN24 Exhaust Temp. High	When this is enabled and the controller detects exhaust temperature has exceeded the pre-set value, it will initiate a block alarm. It is detected after 'safety on time' before 'ETS solenoid hold'.
50	AIN24 Cylinder Temp. Difference High	When this is enabled and the controller detects cylinder temp. difference has exceeded the pre-set value, it will initiate a block alarm. It is detected after 'safety on time' before 'ETS solenoid hold'.
51	AIN24 Sensor Open	When the controller detects the sensor circuit is open, it shall issue a block alarm. It is always detected.
52	AIN24 Sensor High	When over high alarm is enabled, and the controller detects the sensor value is above the preset upper limit, it shall issue a block alarm. It is detected after 'safety on time' before 'ETS solenoid hold' when the sensor is selected as temperature sensor and pressure sensor; It is always detected when the sensor is selected as fuel level sensor.
53	AIN24 Sensor Low	When over low alarm is enabled, and the controller detects the sensor value is below the preset lower limit, it shall issue a block alarm. It is detected after 'safety on time' before 'ETS solenoid hold' when the sensor is selected as temperature sensor and pressure sensor; It is always detected when the sensor is selected as fuel level sensor.
54	Power Factor Low	When this is enabled and the controller detects that the generator power factor has fallen below the pre-set limit, it will initiate a block alarm. It is always detected.
55	THD High	When this is enabled and the controller detects that the THD has exceeded the pre-set limit, it will initiate a block alarm. It is always detected.
56	Gen Volt Unbalance	When this is enabled and the controller detects that the voltage unbalanced value has exceeded the pre-set limit, it will initiate a block alarm. It is always detected.
57	AIN16-M02 Com. Fail	When AIN16-M02 is enabled, and when controller cannot receive the communication data of AIN16-M02 module, controller issues a block signal; It is detected always.
58	AIN16-M02 Sensor Open	When controller detects sensor is open, controller issues an alarm signal; It is detected always.
59	AIN16-M02 Sensor High	When over high alarm is enabled, and the controller detects the sensor value is above the preset upper limit, it shall issue an alarm. It is detected after 'safety on time' before 'ETS solenoid hold' when the sensor is selected as temperature sensor and pressure sensor; It is always detected when the sensor is selected as fuel level sensor.
60	AIN16-M02 Sensor Low	When over low alarm is enabled, and the controller detects the sensor value is below the preset lower limit, it shall issue an alarm.





No	Type	Description
		It is detected after 'safety on time' before 'ETS solenoid hold' when the sensor is selected as temperature sensor and pressure sensor; It is always detected when the sensor is selected as fuel level sensor.
61	AIN8 Com Fail	AIN8 enabled; when controller cannot receive AIN8 module communication data, it will issue alarm signal; It is detected always.
62	AIN8 Sensor Open	When controller detects sensor open, it issues alarm signal; It is detected always.
63	AIN8 Sensor High	Enabled; when the sensor value detected by the controller is over the pre-set upper limit, controller issues alarm signal; When sensor type selects temp sensor and pressure sensor, it is detected after safety on run before ETS stop; It is detected always when sensor type selects liquid level sensor.
64	AIN8 Sensor Low	Enabled; when the sensor value detected by the controller is below the pre-set lower limit, controller issues alarm signal; When sensor type selects temp sensor and pressure sensor, it is detected after safety on run before ETS stop; It is detected always when sensor type selects liquid level sensor.
65	BAC150CAN Com. Fail	When BAC150CAN is enabled, and when controller cannot receive communication data of BAC150CAN module, controller issues an alarm signal; It is always detected.

### 6.3 TRIP ALARM

When controller detects safety trip signals, it will open breaker immediately but not stop the genset. Users need to reset alarms manually.

**Table 9 Safety Trip**

No	Type	Description
1	Over Speed	When this is enabled, and the controller detects that the genset speed is above the pre-set limit, it will initiate an alarm signal. It is always detected.
2	Under Speed	When this is enabled and the controller detects that the genset speed is below the pre-set limit, it will initiate an alarm signal. It is detected after 'warming up' and before 'stop idle'.
3	Loss of Speed Signal	When the controller detects the genset speed is 0, it shall issue an alarm signal. It is detected after 'safety on time' and before 'ETS solenoid hold'.
4	Gen Over Frequency	When this is enabled, and the controller detects the genset frequency is above preset limit, it shall issue an alarm signal. It is detected always.
5	Gen Under Frequency	When this is enabled, and the controller detects the frequency is below the preset limit, it shall issue an alarm signal. It is detected after 'warming up' and before 'stop idle'.
6	Gen Over Voltage	When this is enabled, and the controller detects the genset voltage is above preset limit, it shall issue an alarm signal. It is detected always.
7	Gen Under Voltage	When this is enabled, and the controller detects the voltage is below the preset limit, it shall issue an alarm signal. It is detected after 'warming up' and before 'stop idle'.
8	Gen Over Current	When this is enabled, and the controller detects the genset current is above preset limit, it shall issue an alarm signal. It is detected always.
9	Negative Sequence Current	When this is enabled, and the controller detects the unbalanced current is above preset limit, it shall issue an alarm signal. It is detected always.
10	Earth Fault	When this is enabled, and the controller detects the earth current is above the preset limit, it shall issue an alarm signal. It is always detected.
11	Reverse Power	When this is enabled, and the controller detects the reverse power (negative) is above the preset limit, it shall issue an alarm signal. It is always detected.
12	Over Power	When this is enabled, and the controller detects the genset power (positive) is above the preset limit, it shall issue an alarm signal. It is always detected.
13	Loss Excitation	When this is enabled, and the controller detects the genset reactive



No	Type	Description
		power (negative) is above the preset limit, it shall issue an alarm signal. It is always detected.
14	ECU Alarm	When the controller receives the engine alarm signal from J1939, it shall issue an alarm signal. It is always detected.
15	Temp. Sensor Open	When the controller detects the sensor circuit is open, it shall issue an alarm signal. It is always detected.
16	Engine Temp High	When this is enabled, and the controller detects the temp. is above the preset limit, it shall issue an alarm signal. It is detected after 'safety on time' before 'ETS solenoid hold'.
17	Engine Temp Low	When this is enabled, and the controller detects the temp. is below the preset limit, it shall issue an alarm signal. It is detected after 'safety on time' before 'ETS solenoid hold'.
18	Oil Pressure Sensor Open	When the controller detects the sensor circuit is open, it shall issue an alarm signal. It is always detected.
19	Oil Pressure Low	When this is enabled, and the controller detects the pressure is below the preset limit, it shall issue an alarm signal. It is detected after 'safety on time' before 'ETS solenoid hold'.
20	Oil Pressure Sensor Wrong	When voltage or current input is selected for the curve type of the controller, and the controller detects input signal is abnormal, it shall issue an alarm signal, and meanwhile the curve is transferred to resistor type to prevent damaging the controller. It is detected always.
21	Fuel Level Sensor Open	When the controller detects the sensor circuit is open, it shall issue an alarm signal. It is always detected.
22	Fuel Level Low	When this is enabled, and the controller detects the level is below the preset limit, it shall issue an alarm signal. It is always detected.
23	Fuel Level Sensor Wrong	When voltage or current input is selected for the curve type of the controller, and the controller detects input signal is abnormal, it shall issue an alarm signal, and meanwhile the curve is transferred to resistor type to prevent damaging the controller. It is detected always.
24	Flex. Sensor 1 Open	When the controller detects the sensor circuit is open, it shall issue an alarm signal. It is always detected.
25	Flex. Sensor 1 High	When over high alarm is enabled, and the controller detects the sensor value is above the preset upper limit, it shall issue an alarm signal. It is detected after 'safety on time' before 'ETS solenoid hold' when the sensor is selected as temperature sensor and pressure sensor;



No	Type	Description
		It is always detected when the sensor is selected as fuel level sensor.
26	Flex. Sensor 1 Low	When over low alarm is enabled, and the controller detects the sensor value is below the preset low limit, it shall issue an alarm signal. It is detected after 'safety on time' before 'ETS solenoid hold' when the sensor is selected as temperature sensor and pressure sensor; It is always detected when the sensor is selected as fuel level sensor.
27	Flex. Sensor 1 Wrong	When voltage or current input is selected for the curve type of the controller, and the controller detects input signal is abnormal, it shall issue an alarm signal, and meanwhile the curve is transferred to resistor type to prevent damaging the controller. It is detected always.
28	Flex. Sensor 2 Open	When the controller detects the sensor circuit is open, it shall issue an alarm signal. It is always detected.
29	Flex. Sensor 2 High	When over high alarm is enabled, and the controller detects the sensor value is above the preset upper limit, it shall issue an alarm signal. It is detected after 'safety on time' before 'ETS solenoid hold' when the sensor is selected as temperature sensor and pressure sensor; It is always detected when the sensor is selected as fuel level sensor.
30	Flex. Sensor 2 Low	When over low alarm is enabled, and the controller detects the sensor value is below the preset low limit, it shall issue an alarm signal. It is detected after 'safety on time' before 'ETS solenoid hold' when the sensor is selected as temperature sensor and pressure sensor; It is always detected when the sensor is selected as fuel level sensor.
31	Flex. Sensor 2 Wrong	When voltage or current input is selected for the curve type of the controller, and the controller detects input signal is abnormal, it shall issue an alarm signal, and meanwhile the curve is transferred to resistor type to prevent damaging the controller. It is detected always.
32	Flex. Sensor 3 Open	When the controller detects the sensor circuit is open, it shall issue an alarm signal. It is always detected.
33	Flex. Sensor 3 High	When over high alarm is enabled, and the controller detects the sensor value is above the preset upper limit, it shall issue an alarm signal. It is detected after 'safety on time' before 'ETS solenoid hold' when the sensor is selected as temperature sensor and pressure sensor; It is always detected when the sensor is selected as fuel level sensor.
34	Flex. Sensor 3 Low	When over low alarm is enabled, and the controller detects the sensor value is below the preset low limit, it shall issue an alarm signal. It is detected after 'safety on time' before 'ETS solenoid hold' when the sensor is selected as temperature sensor and pressure sensor; It is always detected when the sensor is selected as fuel level sensor.
35	Charge Alternator	When this is enabled, and the controller detects the charger voltage

No	Type	Description
	Failure	value is below the preset limit, it shall issue an alarm signal. It is detected when the genset is normally running.
36	Battery Over Volt	When this is enabled, and the controller detects the battery voltage is above the preset limit, it shall issue an alarm signal. It is always detected.
37	Battery Under Volt	When this is enabled, and the controller detects the battery voltage is below the preset limit, it shall issue an alarm signal. It is always detected.
38	Fail to Sync.	If the controller doesn't detect sync. signal within the pre-set time, it will initiate an alarm signal. It is detected when GCB closes.
39	Gen Switch Alarm	When sync. transfer is enabled and controller detects gen switch close/open failure, controller issues an alarm signal; It is always detected.
40	Mains Switch Alarm	When sync. transfer is enabled and controller detects mains switch close/open failure, controller issues an alarm signal; It is always detected.
41	Maintenance Time 1 Due	When this is enabled, and when maintenance 1 countdown is equal to maintenance 1 countdown A or maintenance 1 countdown B, or maintenance 1 countdown is 0, controller will initiate an alarm signal. It is detected when the genset is running.
42	Maintenance Time 2 Due	When this is enabled, and when maintenance 2 countdown is equal to maintenance 2 countdown A or maintenance 2 countdown B, or maintenance 2 countdown is 0, controller will initiate an alarm signal. It is detected when the genset is running.
43	Maintenance Time 3 Due	When this is enabled, and when maintenance 3 countdown is equal to maintenance 3 countdown A or maintenance 3 countdown B, or maintenance 3 countdown is 0, controller will initiate an alarm signal. It is detected when the genset is running.
44	Digital Input Alarm	When the digital input port is set users-defined and if it is active, the controller will initiate an alarm signal for the input port. It is detected in the detection range set for the input port.
45	PLC Functions Alarm	When PLC function is set users-defined and if it is active, the controller will initiate an alarm signal. It is detected in the detection range set by the PLC function.
46	DIN16 Com. Fail	When DIN16 communication is enabled and the controller cannot receive the communication data of DIN16, it will initiate an alarm signal. It is always detected.
47	DIN16 Input Alarm	When DIN16 input is set users-defined and if it is active, the controller will initiate an alarm signal. It is detected in the detection range set in the input.
48	DOU16 Com. Fail	When DOU16 communication is enabled and the controller cannot receive the communication data of DOU16, it will initiate an alarm



No	Type	Description
		signal. It is always detected.
49	AIN24 Com. Fail	When AIN24 communication is enabled and the controller cannot receive the communication data of AIN24 module, it will initiate an alarm signal. It is always detected.
50	AIN24 Cylinder Temp. High	When this is enabled and the controller detects cylinder temperature has exceeded the pre-set value, it will initiate an alarm signal. It is detected after 'safety on time' before 'ETS solenoid hold'.
51	AIN24 Exhaust Temp. High	When this is enabled and the controller detects exhaust temperature has exceeded the pre-set value, it will initiate an alarm signal. It is detected after 'safety on time' before 'ETS solenoid hold'.
52	AIN24 Cylinder Temp. Difference High	When this is enabled and the controller detects cylinder temp. difference has exceeded the pre-set value, it will initiate an alarm signal. It is detected after 'safety on time' before 'ETS solenoid hold'.
53	AIN24 Sensor Open	When the controller detects the sensor circuit is open, it shall issue an alarm signal. It is always detected.
54	AIN24 Sensor High	When over high alarm is enabled, and the controller detects the sensor value is above the preset upper limit, it shall issue an alarm signal. It is detected after 'safety on time' before 'ETS solenoid hold' when the sensor is selected as temperature sensor and pressure sensor; It is always detected when the sensor is selected as fuel level sensor.
55	AIN24 Sensor Low	When over low alarm is enabled, and the controller detects the sensor value is below the preset lower limit, it shall issue an alarm signal. It is detected after 'safety on time' before 'ETS solenoid hold' when the sensor is selected as temperature sensor and pressure sensor; It is always detected when the sensor is selected as fuel level sensor.
56	Power Factor Low	When this is enabled and the controller detects that the generator power factor has fallen below the pre-set limit, it will initiate an alarm signal. It is always detected.
57	THD High	When this is enabled and the controller detects that the THD has exceeded the pre-set limit, it will initiate an alarm signal. It is always detected.
58	Gen Volt Unbalance	When this is enabled and the controller detects that the voltage unbalanced value has exceeded the pre-set limit, it will initiate an alarm signal. It is always detected.
59	AIN16-M02 Com. Fail	When AIN16-M02 is enabled, and when controller cannot receive the communication data of AIN16-M02 module, controller issues an alarm signal; It is detected always.
60	AIN16-M02 Sensor	When controller detects sensor is open, controller issues an alarm



No	Type	Description
	Open	signal; It is detected always.
61	AIN16-M02 Sensor High	When over high alarm is enabled, and the controller detects the sensor value is above the preset upper limit, it shall issue an alarm. It is detected after 'safety on time' before 'ETS solenoid hold' when the sensor is selected as temperature sensor and pressure sensor; It is always detected when the sensor is selected as fuel level sensor.
62	AIN16-M02 Sensor Low	When over low alarm is enabled, and the controller detects the sensor value is below the preset lower limit, it shall issue an alarm. It is detected after 'safety on time' before 'ETS solenoid hold' when the sensor is selected as temperature sensor and pressure sensor; It is always detected when the sensor is selected as fuel level sensor.
63	AIN8 Com Fail	AIN8 enabled; when controller cannot receive AIN8 module communication data, it will issue alarm signal; It is detected always.
64	AIN8 Sensor Open	When controller detects sensor open, it issues alarm signal; It is detected always.
65	AIN8 Sensor High	Enabled; when the sensor value detected by the controller is over the pre-set upper limit, controller issues alarm signal; When sensor type selects temp sensor and pressure sensor, it is detected after safety on run before ETS stop; It is detected always when sensor type selects liquid level sensor.
66	AIN8 Sensor Low	Enabled; when the sensor value detected by the controller is below the pre-set lower limit, controller issues alarm signal; When sensor type selects temp sensor and pressure sensor, it is detected after safety on run before ETS stop; It is detected always when sensor type selects liquid level sensor.
67	BAC150CAN Com. Fail	When BAC150CAN is enabled, and when controller cannot receive communication data of BAC150CAN module, controller issues an alarm signal; It is always detected.

#### 6.4 TRIP AND STOP ALARMS

When controller detects trip and stop signals, it will open breaker directly and genset stops after cooling. Users need to reset alarms manually.

**Table 10 Trip Stop Alarms**

No	Type	Description
1	Over Speed	When this is enabled, and the controller detects that the genset speed is above the pre-set limit, it will initiate an alarm signal. It is always detected.
2	Under Speed	When this is enabled and the controller detects that the genset speed is below the pre-set limit, it will initiate an alarm signal.



No	Type	Description
		It is detected after 'warming up' and before 'stop idle'.
3	Loss of Speed Signal	When the controller detects the genset speed is 0, it shall issue an alarm signal. It is detected after 'safety on time' and before 'ETS solenoid hold'.
4	Gen Over Frequency	When this is enabled, and the controller detects the genset frequency is above preset limit, it shall issue an alarm signal. It is detected always.
5	Gen Under Frequency	When this is enabled, and the controller detects the frequency is below the preset limit, it shall issue an alarm signal. It is detected after 'warming up' and before 'stop idle'.
6	Gen Over Voltage	When this is enabled, and the controller detects the genset voltage is above preset limit, it shall issue an alarm signal. It is detected always.
7	Gen Under Voltage	When this is enabled, and the controller detects the voltage is below the preset limit, it shall issue an alarm signal. It is detected after 'warming up' and before 'stop idle'.
8	Gen Over Current	When this is enabled, and the controller detects the genset current is above preset limit, it shall issue an alarm signal. It is detected always.
9	Negative Sequence Current	When this is enabled, and the controller detects the unbalanced current is above preset limit, it shall issue an alarm signal. It is detected always.
10	Earth Fault	When this is enabled, and the controller detects the earth current is above the preset limit, it shall issue an alarm signal. It is always detected.
11	Reverse Power	When this is enabled, and the controller detects the reverse power (negative) is above the preset limit, it shall issue an alarm signal. It is always detected.
12	Over Power	When this is enabled, and the controller detects the genset power (positive) is above the preset limit, it shall issue an alarm signal. It is always detected.
13	Loss Excitation	When this is enabled, and the controller detects the genset reactive power (negative) is above the preset limit, it shall issue an alarm signal. It is always detected.
14	ECU Alarm	When the controller receives the engine alarm signal from J1939, it shall issue an alarm signal. It is always detected.
15	Temp. Sensor Open	When the controller detects the sensor circuit is open, it shall issue an alarm signal. It is always detected.
16	Engine Temp High	When this is enabled, and the controller detects the temp. is above the preset limit, it shall issue an alarm signal. It is detected after 'safety on time' before 'ETS solenoid hold'.



No	Type	Description
17	Engine Temp Low	When this is enabled, and the controller detects the temp. is below the preset limit, it shall issue an alarm signal. It is detected after 'safety on time' before 'ETS solenoid hold'.
18	Oil Pressure Sensor Open	When the controller detects the sensor circuit is open, it shall issue an alarm signal. It is always detected.
19	Oil Pressure Low	When this is enabled, and the controller detects the pressure is below the preset limit, it shall issue an alarm signal. It is detected after 'safety on time' before 'ETS solenoid hold'.
20	Oil Pressure Sensor Wrong	When voltage or current input is selected for the curve type of the controller, and the controller detects input signal is abnormal, it shall issue an alarm signal, and meanwhile the curve is transferred to resistor type to prevent damaging the controller. It is detected always.
21	Fuel Level Sensor Open	When the controller detects the sensor circuit is open, it shall issue an alarm signal. It is always detected.
22	Fuel Level Low	When this is enabled, and the controller detects the level is below the preset limit, it shall issue an alarm signal. It is always detected.
23	Fuel Level Sensor Wrong	When voltage or current input is selected for the curve type of the controller, and the controller detects input signal is abnormal, it shall issue an alarm signal, and meanwhile the curve is transferred to resistor type to prevent damaging the controller. It is detected always.
24	Flex. Sensor 1 Open	When the controller detects the sensor circuit is open, it shall issue an alarm signal. It is always detected.
25	Flex. Sensor 1 High	When over high alarm is enabled, and the controller detects the sensor value is above the preset upper limit, it shall issue an alarm signal. It is detected after 'safety on time' before 'ETS solenoid hold' when the sensor is selected as temperature sensor and pressure sensor; It is always detected when the sensor is selected as fuel level sensor.
26	Flex. Sensor 1 Low	When over low alarm is enabled, and the controller detects the sensor value is below the preset low limit, it shall issue an alarm signal. It is detected after 'safety on time' before 'ETS solenoid hold' when the sensor is selected as temperature sensor and pressure sensor; It is always detected when the sensor is selected as fuel level sensor.
27	Flex. Sensor 1 Wrong	When voltage or current input is selected for the curve type of the controller, and the controller detects input signal is abnormal, it shall issue an alarm signal, and meanwhile the curve is transferred to resistor type to prevent damaging the controller. It is detected always.



No	Type	Description
28	Flex. Sensor 2 Open	When the controller detects the sensor circuit is open, it shall issue an alarm signal. It is always detected.
29	Flex. Sensor 2 High	When over high alarm is enabled, and the controller detects the sensor value is above the preset upper limit, it shall issue an alarm signal. It is detected after 'safety on time' before 'ETS solenoid hold' when the sensor is selected as temperature sensor and pressure sensor; It is always detected when the sensor is selected as fuel level sensor.
30	Flex. Sensor 2 Low	When over low alarm is enabled, and the controller detects the sensor value is below the preset low limit, it shall issue an alarm signal. It is detected after 'safety on time' before 'ETS solenoid hold' when the sensor is selected as temperature sensor and pressure sensor; It is always detected when the sensor is selected as fuel level sensor.
31	Flex. Sensor 2 Wrong	When voltage or current input is selected for the curve type of the controller, and the controller detects input signal is abnormal, it shall issue an alarm signal, and meanwhile the curve is transferred to resistor type to prevent damaging the controller. It is detected always.
32	Flex. Sensor 3 Open	When the controller detects the sensor circuit is open, it shall issue an alarm signal. It is always detected.
33	Flex. Sensor 3 High	When over high alarm is enabled, and the controller detects the sensor value is above the preset upper limit, it shall issue an alarm signal. It is detected after 'safety on time' before 'ETS solenoid hold' when the sensor is selected as temperature sensor and pressure sensor; It is always detected when the sensor is selected as fuel level sensor.
34	Flex. Sensor 3 Low	When over low alarm is enabled, and the controller detects the sensor value is below the preset low limit, it shall issue an alarm signal. It is detected after 'safety on time' before 'ETS solenoid hold' when the sensor is selected as temperature sensor and pressure sensor; It is always detected when the sensor is selected as fuel level sensor.
35	Charge Alternator Failure	When this is enabled, and the controller detects the charger voltage value is below the preset limit, it shall issue an alarm signal. It is detected when the genset is normally running.
36	Battery Over Volt	When this is enabled, and the controller detects the battery voltage is above the preset limit, it shall issue an alarm signal. It is always detected.
37	Battery Under Volt	When this is enabled, and the controller detects the battery voltage is below the preset limit, it shall issue an alarm signal. It is always detected.
38	Maintenance Time 1 Due	When this is enabled, and when maintenance 1 countdown is equal to maintenance 1 countdown A or maintenance 1 countdown B, or maintenance 1 countdown is 0, controller will initiate an alarm signal.



No	Type	Description
		It is detected when the genset is running.
39	Maintenance Time 2 Due	When this is enabled, and when maintenance 2 countdown is equal to maintenance 2 countdown A or maintenance 2 countdown B, or maintenance 2 countdown is 0, controller will initiate an alarm signal. It is detected when the genset is running.
40	Maintenance Time 3 Due	When this is enabled, and when maintenance 3 countdown is equal to maintenance 3 countdown A or maintenance 3 countdown B, or maintenance 3 countdown is 0, controller will initiate an alarm signal. It is detected when the genset is running.
41	Digital Input Alarm	When the digital input port is set users-defined and if it is active, the controller will initiate an alarm signal for the input port. It is detected in the detection range set for the input port.
42	PLC Functions Alarm	When PLC function is set users-defined and if it is active, the controller will initiate an alarm signal. It is detected in the detection range set by the PLC function.
43	DIN16 Com. Fail	When DIN16 communication is enabled and the controller cannot receive the communication data of DIN16, it will initiate an alarm signal. It is always detected.
44	DIN16 Input Alarm	When DIN16 input is set users-defined and if it is active, the controller will initiate an alarm signal. It is detected in the detection range set in the input.
45	DOU16 Com. Fail	When DOU16 communication is enabled and the controller cannot receive the communication data, it will initiate an alarm signal. It is always detected.
46	AIN24 Com. Fail	When AIN24 communication is enabled and the controller cannot receive the communication data of AIN24, it will initiate an alarm signal. It is always detected.
47	AIN24 Cylinder Temp. High	When this is enabled and the controller detects cylinder temperature has exceeded the pre-set value, it will initiate an alarm signal. It is detected after 'safety on time' before 'ETS solenoid hold'.
48	AIN24 Exhaust Temp. High	When this is enabled and the controller detects exhaust temperature has exceeded the pre-set value, it will initiate an alarm signal. It is detected after 'safety on time' before 'ETS solenoid hold'.
49	AIN24 Cylinder Temp. Difference High	When this is enabled and the controller detects cylinder temp. difference has exceeded the pre-set value, it will initiate an alarm signal. It is detected after 'safety on time' before 'ETS solenoid hold'.
50	AIN24 Sensor Open	When the controller detects the sensor circuit is open, it shall issue an alarm signal. It is always detected.
51	AIN24 Sensor High	When over high alarm is enabled, and the controller detects the sensor value is above the preset upper limit, it shall issue an alarm signal. It is detected after 'safety on time' before 'ETS solenoid hold' when the sensor is selected as temperature sensor and pressure sensor;





No	Type	Description
		It is always detected when the sensor is selected as fuel level sensor.
52	AIN24 Sensor Low	When over low alarm is enabled, and the controller detects the sensor value is below the preset lower limit, it shall issue an alarm signal. It is detected after 'safety on time' before 'ETS solenoid hold' when the sensor is selected as temperature sensor and pressure sensor; It is always detected when the sensor is selected as fuel level sensor.
53	Power Factor Low	When this is enabled and the controller detects that the gen power factor has fallen below the pre-set limit, it will initiate an alarm signal. It is always detected.
54	THD High	When this is enabled and the controller detects that the THD has exceeded the pre-set limit, it will initiate an alarm signal. It is always detected.
55	Gen Volt Unbalance	When this is enabled and the controller detects that the voltage unbalanced value has exceeded the pre-set limit, it will initiate an alarm signal. It is always detected.
56	AIN16-M02 Com. Fail	When AIN16-M02 is enabled, and when controller cannot receive the communication data of AIN16-M02 module, controller issues an alarm signal; It is detected always.
57	AIN16-M02 Sensor Open	When controller detects sensor is open, controller issues an alarm signal; It is detected always.
58	AIN16-M02 Sensor High	When over high alarm is enabled, and the controller detects the sensor value is above the preset upper limit, it shall issue an alarm. It is detected after 'safety on time' before 'ETS solenoid hold' when the sensor is selected as temperature sensor and pressure sensor; It is always detected when the sensor is selected as fuel level sensor.
59	AIN16-M02 Sensor Low	When over low alarm is enabled, and the controller detects the sensor value is below the preset lower limit, it shall issue an alarm. It is detected after 'safety on time' before 'ETS solenoid hold' when the sensor is selected as temperature sensor and pressure sensor; It is always detected when the sensor is selected as fuel level sensor.
60	AIN8 Com Fail	AIN8 enabled; when controller cannot receive AIN8 module communication data, it will issue alarm signal; It is detected always.
61	AIN8 Sensor Open	When controller detects sensor open, it issues alarm signal; It is detected always.
62	AIN8 Sensor High	Enabled; when the sensor value detected by the controller is over the pre-set upper limit, controller issues alarm signal; When sensor type selects temp sensor and pressure sensor, it is detected after safety on run before ETS stop; It is detected always when sensor type selects liquid level sensor.





No	Type	Description
63	AIN8 Sensor Low	Enabled; when the sensor value detected by the controller is below the pre-set lower limit, controller issues alarm signal; When sensor type selects temp sensor and pressure sensor, it is detected after safety on run before ETS stop; It is detected always when sensor type selects liquid level sensor.
64	BAC150CAN Com. Fail	When BAC150CAN is enabled, and when controller cannot receive communication data of BAC150CAN module, controller issues an alarm signal; It is always detected.

SmartGen

## 6.5 SHUTDOWN ALARMS

When controller detects shutdown alarms, it will open breaker directly and shut down the generator. Users need to reset alarms manually.

**Table 11 Shutdown Alarms**

No	Type	Description
1	Emergency Stop	When the controller detects emergency stop signals, it will initiate a shutdown alarm signal. It is always detected.
2	Over Speed	When this is enabled, and the controller detects that the genset speed is above the pre-set limit, it will initiate an alarm signal. It is always detected.
3	Under Speed	When this is enabled and the controller detects that the genset speed is below the pre-set limit, it will initiate an alarm signal. It is detected after 'warming up' and before 'stop idle'.
4	Loss of Speed Signal	When the controller detects the genset speed is 0, it shall issue an alarm signal. It is detected after 'safety on time' and before 'ETS solenoid hold'.
5	Gen Over Frequency	When this is enabled, and the controller detects the genset frequency is above preset limit, it shall issue an alarm signal. It is detected always.
6	Gen Under Frequency	When this is enabled, and the controller detects the frequency is below the preset limit, it shall issue an alarm signal. It is detected after 'warming up' and before 'stop idle'.
7	Gen Over Voltage	When this is enabled, and the controller detects the genset voltage is above preset limit, it shall issue an alarm signal. It is detected always.
8	Gen Under Voltage	When this is enabled, and the controller detects the voltage is below the preset limit, it shall issue an alarm signal. It is detected after 'warming up' and before 'stop idle'.
9	Gen Over Current	When this is enabled, and the controller detects the genset current is above preset limit, it shall issue an alarm signal. It is detected always.
10	Negative Sequence Current	When this is enabled, and the controller detects the unbalanced current is above preset limit, it shall issue an alarm signal. It is detected always.
11	Earth Fault	When this is enabled, and the controller detects the earth current is above the preset limit, it shall issue an alarm signal. It is always detected.
12	Reverse Power	When this is enabled, and the controller detects the reverse power (negative) is above the preset limit, it shall issue an alarm signal. It is always detected.
13	Over Power	When this is enabled, and the controller detects the genset power



No	Type	Description
		(positive) is above the preset limit, it shall issue an alarm signal. It is always detected.
14	Loss Excitation	When this is enabled, and the controller detects the genset reactive power (negative) is above the preset limit, it shall issue an alarm signal. It is always detected.
15	ECU Alarm	When the controller receives the engine alarm signal from J1939, it shall issue an alarm signal. It is always detected.
16	Temp. Sensor Open	When the controller detects the sensor circuit is open, it shall issue an alarm signal. It is always detected.
17	Engine Temp High	When this is enabled, and the controller detects the temp. is above the preset limit, it shall issue an alarm signal. It is detected after 'safety on time' before 'ETS solenoid hold'.
18	Engine Temp Low	When this is enabled, and the controller detects the temp. is below the preset limit, it shall issue an alarm signal. It is detected after 'safety on time' before 'ETS solenoid hold'.
19	Oil Pressure Sensor Open	When the controller detects the sensor circuit is open, it shall issue an alarm signal. It is always detected.
20	Oil Pressure Low	When this is enabled, and the controller detects the pressure is below the preset limit, it shall issue an alarm signal. It is detected after 'safety on time' before 'ETS solenoid hold'.
21	Oil Pressure Sensor Wrong	When voltage or current input is selected for the curve type of the controller, and the controller detects input signal is abnormal, it shall issue an alarm signal, and meanwhile the curve is transferred to resistor type to prevent damaging the controller. It is detected always.
22	Fuel Level Sensor Open	When the controller detects the sensor circuit is open, it shall issue an alarm signal. It is always detected.
23	Fuel Level Low	When this is enabled, and the controller detects the level is below the preset limit, it shall issue an alarm signal. It is always detected.
24	Fuel Level Sensor Wrong	When voltage or current input is selected for the curve type of the controller, and the controller detects input signal is abnormal, it shall issue an alarm signal, and meanwhile the curve is transferred to resistor type to prevent damaging the controller. It is detected always.
25	Flex. Sensor 1 Open	When the controller detects the sensor circuit is open, it shall issue an alarm signal. It is always detected.
26	Flex. Sensor 1 High	When over high alarm is enabled, and the controller detects the sensor



No	Type	Description
		value is above the preset upper limit, it shall issue an alarm signal. It is detected after 'safety on time' before 'ETS solenoid hold' when the sensor is selected as temperature sensor and pressure sensor; It is always detected when the sensor is selected as fuel level sensor.
27	Flex. Sensor 1 Low	When over low alarm is enabled, and the controller detects the sensor value is below the preset low limit, it shall issue an alarm signal. It is detected after 'safety on time' before 'ETS solenoid hold' when the sensor is selected as temperature sensor and pressure sensor; It is always detected when the sensor is selected as fuel level sensor.
28	Flex. Sensor 1 Wrong	When voltage or current input is selected for the curve type of the controller, and the controller detects input signal is abnormal, it shall issue an alarm signal, and meanwhile the curve is transferred to resistor type to prevent damaging the controller. It is detected always.
29	Flex. Sensor 2 Open	When the controller detects the sensor circuit is open, it shall issue an alarm signal. It is always detected.
30	Flex. Sensor 2 High	When over high alarm is enabled, and the controller detects the sensor value is above the preset upper limit, it shall issue an alarm signal. It is detected after 'safety on time' before 'ETS solenoid hold' when the sensor is selected as temperature sensor and pressure sensor; It is always detected when the sensor is selected as fuel level sensor.
31	Flex. Sensor 2 Low	When over low alarm is enabled, and the controller detects the sensor value is below the preset low limit, it shall issue an alarm signal. It is detected after 'safety on time' before 'ETS solenoid hold' when the sensor is selected as temperature sensor and pressure sensor; It is always detected when the sensor is selected as fuel level sensor.
32	Flex. Sensor 2 Wrong	When voltage or current input is selected for the curve type of the controller, and the controller detects input signal is abnormal, it shall issue an alarm signal, and meanwhile the curve is transferred to resistor type to prevent damaging the controller. It is detected always.
33	Flex. Sensor 3 Open	When the controller detects the sensor circuit is open, it shall issue an alarm signal. It is always detected.
34	Flex. Sensor 3 High	When over high alarm is enabled, and the controller detects the sensor value is above the preset upper limit, it shall issue an alarm signal. It is detected after 'safety on time' before 'ETS solenoid hold' when the sensor is selected as temperature sensor and pressure sensor; It is always detected when the sensor is selected as fuel level sensor.
35	Flex. Sensor 3 Low	When over low alarm is enabled, and the controller detects the sensor value is below the preset low limit, it shall issue an alarm signal. It is detected after 'safety on time' before 'ETS solenoid hold' when the



No	Type	Description
		sensor is selected as temperature sensor and pressure sensor; It is always detected when the sensor is selected as fuel level sensor.
36	Charge Alternator Failure	When this is enabled, and the controller detects the charger voltage value is below the preset limit, it shall issue an alarm signal. It is detected when the genset is normally running.
37	Battery Over Volt	When this is enabled, and the controller detects the battery voltage is above the preset limit, it shall issue an alarm signal. It is always detected.
38	Battery Under Volt	When this is enabled, and the controller detects the battery voltage is below the preset limit, it shall issue an alarm signal. It is always detected.
39	Maintenance Time 1 Due	When this is enabled, and when maintenance 1 countdown is equal to maintenance 1 countdown A or maintenance 1 countdown B, or maintenance 1 countdown is 0, controller will initiate an alarm signal. It is detected when the genset is running.
40	Maintenance Time 2 Due	When this is enabled, and when maintenance 2 countdown is equal to maintenance 2 countdown A or maintenance 2 countdown B, or maintenance 2 countdown is 0, controller will initiate an alarm signal. It is detected when the genset is running.
41	Maintenance Time 3 Due	When this is enabled, and when maintenance 3 countdown is equal to maintenance 3 countdown A or maintenance 3 countdown B, or maintenance 3 countdown is 0, controller will initiate an alarm signal. It is detected when the genset is running.
42	Gen Reverse Phase	When controller detects gen reverse phase sequence, it issues alarm signal; Gen reverse phase is enabled, it is detected when 3Ph 4W or 2Ph 3W phase voltage is over 30V, 3Ph 3W line voltage is over 50V;
43	Gen Loss of Phase	When controller detects gen loss of phase, it issues an alarm signal; Gen loss of phase is enabled, it is detected when 3Ph 4W or 2Ph 3W phase voltage is over 30V, 3Ph 3W line voltage is over 50V;
44	Digital Input Alarm	When the digital input port is set users-defined and if it is active, the controller will initiate an alarm signal for the input port. It is detected in the detection range set for the input port.
45	PLC Functions Alarm	When PLC function is set users-defined and if it is active, the controller will initiate an alarm signal. It is detected in the detection range set by the PLC function.
46	DIN16 Com. Fail	When DIN16 communication is enabled and the controller cannot receive the communication data, it will initiate an alarm signal. It is always detected.
47	DIN16 Input Alarm	When DIN16 input is set users-defined and if it is active, the controller will initiate an alarm signal. It is detected in the detection range set in the input.
48	DOU16 Com. Fail	When DOU16 communication is enabled and the controller cannot



No	Type	Description
		receive the communication data, it will initiate an alarm signal. It is always detected.
49	AIN24 Com. Fail	When AIN24 communication is enabled and the controller cannot receive the communication data, it will initiate an alarm signal. It is always detected.
50	AIN24 Cylinder Temp. High	When this is enabled and the controller detects cylinder temperature has exceeded the pre-set value, it will initiate an alarm signal. It is detected after 'safety on time' before 'ETS solenoid hold'.
51	AIN24 Exhaust Temp. High	When this is enabled and the controller detects exhaust temperature has exceeded the pre-set value, it will initiate an alarm signal. It is detected after 'safety on time' before 'ETS solenoid hold'.
52	AIN24 Cylinder Temp. Difference High	When this is enabled and the controller detects cylinder temp. difference has exceeded the pre-set value, it will initiate an alarm signal. It is detected after 'safety on time' before 'ETS solenoid hold'.
53	AIN24 Sensor Open	When the controller detects the sensor circuit is open, it shall issue an alarm signal. It is always detected.
54	AIN24 Sensor High	When over high alarm is enabled, and the controller detects the sensor value is above the preset upper limit, it shall issue an alarm signal. It is detected after 'safety on time' before 'ETS solenoid hold' when the sensor is selected as temperature sensor and pressure sensor; It is always detected when the sensor is selected as fuel level sensor.
55	AIN24 Sensor Low	When over low alarm is enabled, and the controller detects the sensor value is below the preset lower limit, it shall issue an alarm signal. It is detected after 'safety on time' before 'ETS solenoid hold' when the sensor is selected as temperature sensor and pressure sensor; It is always detected when the sensor is selected as fuel level sensor.
56	Power Factor Low	When this is enabled and the controller detects that the generator power factor has fallen below the pre-set limit, it will initiate an alarm signal. It is always detected.
57	THD High	When this is enabled and the controller detects that the THD has exceeded the pre-set limit, it will initiate an alarm signal. It is always detected.
58	Gen Volt Unbalance	When this is enabled and the controller detects that the voltage unbalanced value has exceeded the pre-set limit, it will initiate an alarm signal. It is always detected.
59	AIN16-M02 Com. Fail	When AIN16-M02 is enabled, and when controller cannot receive the communication data of AIN16-M02 module, controller issues an alarm signal; It is detected always.
60	AIN16-M02 Sensor Open	When controller detects sensor is open, controller issues an alarm signal;





No	Type	Description
		It is detected always.
61	AIN16-M02 Sensor High	When over high alarm is enabled, and the controller detects the sensor value is above the preset upper limit, it shall issue an alarm. It is detected after 'safety on time' before 'ETS solenoid hold' when the sensor is selected as temperature sensor and pressure sensor; It is always detected when the sensor is selected as fuel level sensor.
62	AIN16-M02 Sensor Low	When over low alarm is enabled, and the controller detects the sensor value is below the preset lower limit, it shall issue an alarm. It is detected after 'safety on time' before 'ETS solenoid hold' when the sensor is selected as temperature sensor and pressure sensor; It is always detected when the sensor is selected as fuel level sensor.
63	AIN8 Com Fail	AIN8 enabled; when controller cannot receive AIN8 module communication data, it will issue alarm signal; It is detected always.
64	AIN8 Sensor Open	When controller detects sensor open, it issues alarm signal; It is detected always.
65	AIN8 Sensor High	Enabled; when the sensor value detected by the controller is over the pre-set upper limit, controller issues alarm signal; When sensor type selects temp sensor and pressure sensor, it is detected after safety on run before ETS stop; It is detected always when sensor type selects liquid level sensor.
66	AIN8 Sensor Low	Enabled; when the sensor value detected by the controller is below the pre-set lower limit, controller issues alarm signal; When sensor type selects temp sensor and pressure sensor, it is detected after safety on run before ETS stop; It is detected always when sensor type selects liquid level sensor.
67	BAC150CAN Com. Fail	When BAC150CAN is enabled, and when controller cannot receive communication data of BAC150CAN module, controller issues an alarm signal; It is always detected.

## 7 WIRING CONNECTION

HGM9420N\_HGM9420LT controller back panel is as below:

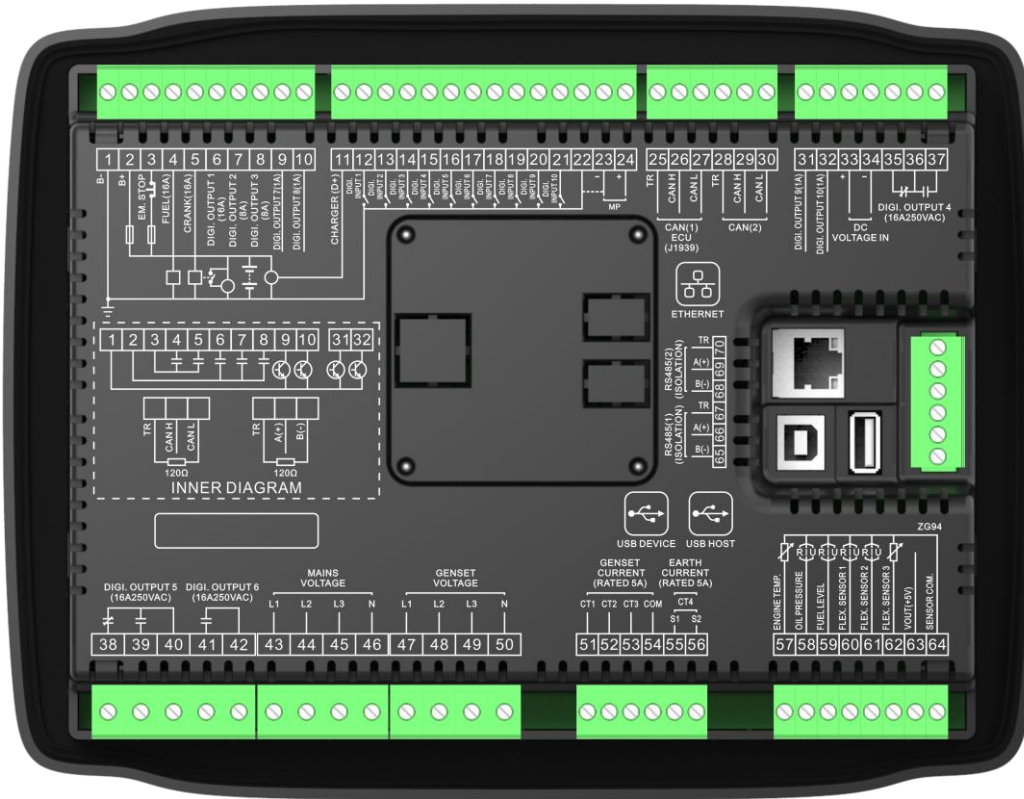

**Fig. 4 Controller Rear Panel**

**Table 12 Terminal Connection Description**

No.	Functions	Cable Size	Remark
1	B-	2.5mm <sup>2</sup>	Connect with starter battery negative.
2	B+	2.5mm <sup>2</sup>	Connect with starter battery positive. If wire length is over 30m, it's better to double wires in parallel. Max. 20A fuse is recommended.
3	Emergency Stop Input	2.5mm <sup>2</sup>	Connect with B+ via emergency stop button.
4	Fuel Relay Output	1.5mm <sup>2</sup>	B+ is supplied by 3 points, rated 16A.
5	Crank Relay Output	1.5mm <sup>2</sup>	B+ is supplied by 3 points, rated 16A. Connect to starter coil.
6	Digi. Output 1	1.5mm <sup>2</sup>	B+ is supplied by 2 points, rated 8A.
7	Digi. Output 2	1.5mm <sup>2</sup>	B+ is supplied by 2 points, rated 8A.
8	Digi. Output 3	1.5mm <sup>2</sup>	B+ is supplied by 2 points, rated 8A.
9	Digi. Output 7	1.5mm <sup>2</sup>	DC30V supply (negative) output (transistor), rated 1A.
10	Digi. Output 8	1.5mm <sup>2</sup>	DC30V supply (negative) output (transistor), rated 1A.
11	Charger (D+)	1.0mm <sup>2</sup>	Connect with Charger D+ (WL) terminal. If this terminal doesn't exist, hang it in the air.
12	Digi. Input 1	1.0mm <sup>2</sup>	Ground connected is active (B-).



No.	Functions	Cable Size	Remark
13	Digi. Input 2	1.0mm <sup>2</sup>	Ground connected is active (B-).
14	Digi. Input 3	1.0mm <sup>2</sup>	Ground connected is active (B-).
15	Digi. Input 4	1.0mm <sup>2</sup>	Ground connected is active (B-).
16	Digi. Input 5	1.0mm <sup>2</sup>	Ground connected is active (B-).
17	Digi. Input 6	1.0mm <sup>2</sup>	Ground connected is active (B-).
18	Digi. Input 7	1.0mm <sup>2</sup>	Ground connected is active (B-).
19	Digi. Input 8	1.0mm <sup>2</sup>	Ground connected is active (B-).
20	Digi. Input 9	1.0mm <sup>2</sup>	Ground connected is active (B-).
21	Digi. Input 10	1.0mm <sup>2</sup>	Ground connected is active (B-).
22	Magnetic pickup shield	0.5mm <sup>2</sup>	Connect with speed sensor, and shielding line is recommended. B- is already connected with speed sensor input 2 in the inside controller.
23	MP2		
24	MP1		
25	ECU TR	/	Impedance-120Ω shielding wire is recommended, and the single-end shall be earth connected. Short connect TR with H and then connect to 120Ω terminal resistor.
26	ECU CAN H	0.5mm <sup>2</sup>	
27	ECU CAN L	0.5mm <sup>2</sup>	
28	CAN(2) TR	/	Impedance-120Ω shielding wire is recommended, and the single-end shall be earth connected. Short connect TR with H and then connect to 120Ω terminal resistor.
29	CAN(2) CAN H	0.5mm <sup>2</sup>	
30	CAN(2) CAN L	0.5mm <sup>2</sup>	
31	Digi. Output 9	1.5mm <sup>2</sup>	DC 30V supply (negative) output (transistor), rated 1A.
32	Digi. Output 10	1.5mm <sup>2</sup>	DC 30V supply (negative) output (transistor), rated 1A.
33	DC Voltage In +	1.0mm <sup>2</sup>	Connect DC battery pack externally.
34	DC Voltage In -	1.0mm <sup>2</sup>	
35	Digi. Output 4	2.5mm <sup>2</sup>	Normally close output, rated 16A.
36			Public points of relay.
37			Normally open output, rated 16A.
38	Digi. Output 5	2.5mm <sup>2</sup>	Normally close output, rated 16A.
39			Public points of relay.
40			Normally open output, rated 16A.
41	Digi. Output 6	2.5mm <sup>2</sup>	Normally open output, rated 16A.
42			Public points of relay.
43	Mains L1 Phase Voltage Input	1.0mm <sup>2</sup>	Connect to Mains L1 Phase (2A fuse is recommended).
44	Mains L2 Phase Voltage Input	1.0mm <sup>2</sup>	Connect to Mains L2 Phase (2A fuse is recommended).
45	Mains L3 Phase Voltage Input	1.0mm <sup>2</sup>	Connect to Mains L3 Phase (2A fuse is recommended).
46	Mains N Wire Input	1.0mm <sup>2</sup>	Connect to Mains N wire.
47	Gen L1 Phase Voltage Input	1.0mm <sup>2</sup>	Connect to Gen L1 Phase (2A fuse is recommended).
48	Gen L2 Phase Voltage Input	1.0mm <sup>2</sup>	Connect to Gen L2 Phase (2A fuse is recommended).



No.	Functions	Cable Size	Remark
49	Gen L3 Phase Voltage Input	1.0mm <sup>2</sup>	Connect to Gen L3 Phase (2A fuse is recommended).
50	Gen N Wire Input	1.0mm <sup>2</sup>	Connect to Gen output N wire.
51	CT A-phase Input	1.5mm <sup>2</sup>	Connect to CT secondary coil (rated 5A) externally.
52	CT B-phase Input	1.5mm <sup>2</sup>	Connect to CT secondary coil (rated 5A) externally.
53	CT C-phase Input	1.5mm <sup>2</sup>	Connect to CT secondary coil (rated 5A) externally.
54	CT COM	1.5mm <sup>2</sup>	Please refer to following installation illustration.
55	Earth CT Input	1.5mm <sup>2</sup>	Outside connect to CT secondary coil (rated 5A).
56		1.5mm <sup>2</sup>	
57	Engine Temp. Sensor	1.0mm <sup>2</sup>	Connect to temperature resistance sensor.
58	Oil Pressure Sensor	1.0mm <sup>2</sup>	Connect to engine oil pressure sensor. Voltage type (0V-10V), current type (4mA-20mA) and resistance sensor can be chosen.
59	Fuel Level Sensor	1.0mm <sup>2</sup>	Connect to fuel level resistance sensor. Voltage type (0V-10V), current type (4mA-20mA) and resistance sensor can be chosen.
60	Flex. Sensor 1	1.0mm <sup>2</sup>	Connect to temp. /fuel level/pressure type sensor. Voltage type (0V-10V), current type (4mA-20mA) and resistance sensor can be chosen.
61	Flex. Sensor 2	1.0mm <sup>2</sup>	Connect to temp. /fuel level/pressure type sensor. Voltage type (0V-10V), current type (4mA-20mA) and resistance sensor can be chosen.
62	Flex. Sensor 3	1.0mm <sup>2</sup>	Connect to temp. /fuel level/pressure resistance sensor.
63	VOUT(+5V)	1.0mm <sup>2</sup>	Provide +5V voltage for voltage type sensor, and current is below 50mA.
64	Sensor COM.	/	Public sensor terminal, and battery negative is already connected in the controller.
65	RS485(1) B(-)	0.5mm <sup>2</sup>	Impedance-120Ω shielding wire is recommended, and the single-end shall be earth connected. Short connect TR with A(+) and then connect to 120Ω terminal resistor.
66	RS485(1) A(+)	0.5mm <sup>2</sup>	
67	RS485(1) TR	/	
68	RS485(2) B(-)	0.5mm <sup>2</sup>	Impedance-120Ω shielding wire is recommended, and the single-end shall be earth connected. Short connect TR with A(+) and then connect to 120Ω terminal resistor.
69	RS485(2) A(+)	0.5mm <sup>2</sup>	
70	RS485(2) TR	/	

**NOTE 1:** USB ports on the controller rear panel are configurable parameter ports, and users can directly program the controller on PC.

**NOTE 2:** The main USB port on the controller rear panel is U flash, by which controller parameters can be lead in or export out.

**NOTE 3:** Expansion SGE02-4G module can be inserted on the back panel.

## 8 SCOPES AND DEFINITIONS OF PROGRAMMABLE PARAMETERS

### 8.1 CONTENTS AND SCOPES OF PARAMETERS

**Table 13 Parameter Configuration Contents and Range**

No.	Items	Parameters	Defaults	Description
<b>Module Setting</b>				
1.	Power On Mode	(0-2)	0	0: Stop Mode 1: Manual Mode 2: Auto Mode
2.	Module Address	(1-254)	1	Controller address for remote monitoring
3.	Language	(0-2)	0	0: Simplified Chinese 1: English 2: Other
4.	Password	(0-65535)	00318	It is used to enter advanced parameter setting.
5.	Daylight Saving Time	(0-1)	0	0: Disable 1: Enable Start and end time for this can be set.
6.	Date and Time			It is used for date and time settings.
7.	Temperature Unit	(0-1)	0	0: °C; 1: °F
8.	Pressure Unit	(0-2)	0	0: kPa 1: psi 2: bar
9.	Backlight Time	(0-3600)s	300	
10.	Network	(0-1)	1	0: Disable 1: Enable
11.	J1939-75	(0-1)	0	0: Disable 1: Enable
12.	Alarm Data Interv.	(0-60.0)s	0.1	
13.	Custom Protocol	(0-1)	0	0: Disable 1: Enable
14.	Fn Function	(0-6)	0	0: Fn Button 1: Stop Button 2: Start Button 3: Manual Button 4: Auto Button 5: Mains Load Btn 6: Gen Load Btn
<b>Mains Setting</b>				
1.	Mains Options	(0-2)	1	0: Disable; 1: AMF; 2: Only Indication
2.	AC System	(0-3)	0	0: 3P4W 1: 3P3W 2: 2P3W 3: 1P2W





No.	Items	Parameters	Defaults	Description
3.	Normal Time	(0-3600)s	10	Check time from Mains abnormal to normal;
4.	Abnormal Time	(0-3600)s	5	Check time from Mains normal to abnormal;
5.	Loss of Phase	(0-1)	1	0: Disable; 1: Enable
6.	Phase Seq. Wrong	(0-1)	1	
7.	Rated Voltage	(30-30000)V	230	Provide standards for Mains overvoltage and undervoltage; if PT is fitted, this value is primary voltage of PT;
8.	PT Fitted	(0-1)	0	0: Disable; 1: Enable
9.	Over Voltage	(0-1)	1	Set value is percentage of Mains rated voltage; Return and delay value can also be set.
		(0-200)%	120	
(0-200)%	116			
(0-3600)s	5			
10.	Under Voltage	(0-1)	1	
		(0-200)%	80	
		(0-200)%	84	
(0-3600)s	5			
11.	Rated Frequency	(10.0-75.0)Hz	50.0	Provide standards for Mains over frequency and under frequency.
12.	Over Frequency	(0-1)	0	Set value is percentage of Mains rated frequency; Return value and delay value can also be set.
		(0-200.0)%	114.0	
		(0-200.0)%	110.0	
(0-3600)s	5			
13.	Under Frequency	(0-1)	0	
		(0-200.0)%	90.0	
		(0-200.0)%	94.0	
(0-3600)s	5			
<b>Timer Setting</b>				
1.	Start Delay	(0~3600)s	5	Time from mains abnormal or remote start signal is active to genset is starting.
2.	Stop Delay	(0~3600)s	30	Time from mains abnormal or remote start signal is active to genset is stopping.
3.	Pre-heat Delay	(0~3600)s	0	Time for pre-powering the heat plug before starter is powered up.
4.	Fuel Delay	(1-3600)s	1	Fuel output time before crank output.
5.	Cranking Time	(3~60)s	8	Time for starter power on each time.
6.	Crank Rest Time	(3~60)s	10	The waiting time before second power up when engine start fails.
7.	Safety On Time	(0-3600)s	10	Alarms for low oil pressure, high temperature, under speed, under frequency /voltage, charge fail are inactive.
8.	Start Idle Time	(0~3600)s	10	Running time for genset idling speed when the genset is starting.





No.	Items	Parameters	Defaults	Description
9.	Warming Up Time	(0~3600)s	30	Warming up time between genset switch on and high speed running.
10.	Cooling Time	(0~3600)s	60	Radiating time before genset stop, after it unloads.
11.	Stop Idle Time	(0~3600)s	10	Running time for genset idling speed when the genset is stopping.
12.	ETS Hold Time	(0~3600)s	20	Time for the stop electromagnet energization as the genset is stopping.
13.	Fail to Stop	(0~3600)s	0	Time after 'idle delay' is over before the complete stop when 'ETS Hold Time' is set "0"; time after 'ETS Hold Time' delay is over before the complete stop when it is set other than "0".
14.	After Stop Time	(0~3600)s	0	Time between a complete stop and standby.
15.	Gas Engine Timers	(0-1)	0	0: Disable 1: Enable
16.	Choke On Time	(0-60)s	0	Output time for gas thickening after the engine starts.
17.	Gas On Delay	(0-60)s	0	
18.	Ignition Off	(0-60)s	0	
19.	Smart Pre-heat	(0-1) (0-3) (0-300)°C	0 0 40	0: Disable 1: Enable When it is enabled, the controller will stop pre-heating earlier according to the set conditions. Sensors are available, and when it is above the set value, it shall end the pre-heating.
20.	Smart Start Idle	(0-1) (0-3) (0-300)°C	0 0 50	0: Disable 1: Enable When it is enabled, the controller will stop pre-heating earlier according to the set conditions. Sensors are available, and when it is above the set value, it shall end start idle process.
<b>Engine Setting</b>				
1.	Engine Type	(0~39)	0	Default: non-ECU engine
2.	Flywheel Teeth	(10~300)	118	Tooth number of the engine, for judging of starter separation conditions and inspecting of engine speed. See back installation instructions.
3.	Rated Speed	(0~6000)r/min	1500	Offer standard to judge over/under/loading speed.
4.	Loading Speed	(0~100.0)%	90.0	Set value is percentage of rated speed. Controller detects when it is ready to load. It won't enter normal running period when



No.	Items	Parameters	Defaults	Description
				speed is under loading speed.
5.	Start Attempts	(1-10) times	3	Maximum start times for start failures; when it reaches up to the set value, controller will issue failed to start signal.
6.	Disc. Condition	(0-6)	2	Please refer to Table 17. 3 kinds of conditions for starter and engine separation; the 3 can be used separately, or used simultaneously; purpose is to separate motor and engine as soon as possible.
7.	Disconnect Freq	(0-200)%	24	Set value is gen rated frequency percentage; when gen freq is above pre-set value, starter will separate; Please refer to back installation illustration.
8.	Disconnect Speed	(0-200)%	24	Set value is rated speed percentage; when speed is above pre-set value, starter will separate; Please refer to back installation illustration.
9.	Disconnect OP	(0-1000)kPa	200	When engine oil pressure is above pre-set value, starter will separate; Please refer to back installation illustration.
10.	ECU Malfunc. Lamp	(0-5)	1	0: None; 1: Warning; 2: Block; 3: Trip; 4: Trip Stop; 5: Shutdown
11.	ECU Stop Lamp	(0-5)	5	
12.	ECU Warning Lamp	(0-5)	1	
13.	ECU Protect Lamp	(0-5)	1	
14.	Battery Voltage	(0-60.0)V	24.0	Provide standards for battery over voltage and under voltage.
15.	Battery OV 1	(0-1)	1	0: Disable 1: Enable
		(0-200.0)%	120.0	Set value is batt. rated volt percentage.
		(0-200.0)%	115.0	Return value is batt. rated volt percentage.
		(0-3600)s	60	Delay value
16.	Battery OV 2	(0-1)	0	0: Disable 1: Enable
		(0-200.0)%	120.0	Set value is batt. rated volt percentage.
		(0-200.0)%	115.0	Return value is batt. rated volt percentage.
		(0-3600)s	60	Delay value
17.	Battery UV 1	(0-1)	1	0: Disable 1: Enable
		(0-200.0)%	85.0	Set value is batt. rated volt percentage.
		(0-200.0)%	90.0	Return value is batt. rated volt percentage.
		(0-3600)s	60	Delay value
18.	Battery UV 2	(0-1)	0	0: Disable 1: Enable
		(0-200.0)%	85.0	Set value is batt. rated volt percentage.



No.	Items	Parameters	Defaults	Description
		(0-200.0)% (0-3600)s (0-5)	90.0 60 0	Return value is batt. rated volt percentage. Delay value Action
19.	Charge Alt Fail	(0-1) (0-60.0)V (0-60.0)V (0-3600)s (0-5)	1 8.0 10.0 10 1	0: Disable    1: Enable Set Value Return Value Delay Value Action
20.	DC Volt. Start	(0-1) (0-60.0)V (0-60.0)V (0-3600)s	0 46.6 53.8 60	0: Disable    1: Enable Start Value Stop Value Delay Value
21.	Loss of Speed Delay	(0-3600)s	5	Time from detecting speed is 0 to action check.
22.	Loss of Speed Act	(0-5)	5	0: None; 1: Warning; 2: Block; 3: Trip; 4: Trip Stop; 5: Shutdown
23.	Over Speed Stop	(0-200)%	114	Set value is rated speed percentage; delay value can also be set.
24.	Under Speed Stop	(0-200)%	80	Set value is rated speed percentage; return value and delay value can also be set.
25.	Over Speed Warn	(0-200)%	110	
26.	Under Speed Warn	(0-200)%	86	
27.	Battery Voltage	(0-60.0)V	24.0	Provide standards for battery over voltage and under voltage;
28.	Battery OV Warn	(0-200)%	120	Set value is percentage of battery rated voltage; return value and delay value can also be set.
29.	Battery UV Warn	(0-200)%	85	
30.	Charge Alt Fail	(0-60.0)V	8.0	During genset normal running process, when charger D+ (WL) voltage is lower than this value, it issues failure warning;
31.	Over Speed 1	(0-1) (0-200.0)% (0-200.0)% (0-3600)s (0-5)	1 114.0 112.0 2 5	0: Disable    1:Enable Set value is rated speed percentage; Return value is rated speed percentage; Delay value Action
32.	Over Speed 2	(0-1) (0-200.0)% (0-200.0)% (0-3600)s (0-5)	1 110.0 108.0 5 1	0: Disable    1:Enable Set value is rated speed percentage; Return value is rated speed percentage; Delay value Action
33.	Under Speed 1	(0-1) (0-200.0)% (0-200.0)%	1 80.0 82.0	0: Disable    1:Enable Set value is rated speed percentage; Return value is rated speed percentage;



No.	Items	Parameters	Defaults	Description
		(0-3600)s	3	Delay value
		(0-5)	5	Action
34.	Under Speed 2	(0-1) (0-200.0)% (0-200.0)% (0-3600)s (0-5)	1 86.0 90.0 5 1	0: Disable 1:Enable Set value is rated speed percentage; Return value is rated speed percentage; Delay value Action
35.	Loss of Speed Act	(0-5)	5	0: None; 1: Warning; 2: Block; 3: Trip; 4: Trip Stop; 5: Shutdown
36.	Loss of Speed Delay	(0-3600)s	5	Time from detecting speed is 0 to action confirm.
<b>Generator Setting</b>				
1.	AC System	(0~3)	0	0: 3P4W; 1: 3P3W; 2: 2P3W; 3: 1P2W.
2.	Poles	(2-64)	4	Numbers of generator poles; this value is used for engine speed calculation when speed sensor is not installed.
3.	Rated Voltage	(30~30000)V	230	Provide standards for judging gen over voltage, under voltage and loading voltage. If PT is fitted, this is primary voltage of PT; when AC system is 3P3W, this value is line voltage; for other AC systems, this value is phase voltage.
4.	Loading Voltage	(0-200.0)%	85.0	Set value is rated voltage percentage; controller detected when it prepares to take load; when gen voltage is less than loading voltage, genset won't enter normal running period.
5.	Rated Frequency	(10.0-75.0) Hz	50.0	Offer standards for detecting over/under/load frequency.
6.	Loading Frequency	(0-200.0)%	85.0	Percentage of generator rated frequency; controller detects when it prepares to take load; when gen frequency is less than loading frequency, it won't enter normal running period.
7.	PT Fitted	(0~1)	0	0: Disable; 1:Enable
8.	Harmonic Display	(0-1)	0	0: Disable 1: Enable
9.	Loss of Phase	(0-1)	1	0: Disable 1: Enable
10.	Phase Seq. Wrong	(0-1)	1	0: Disable 1: Enable
11.	Over Volt 1	(0-1) (0-200.0)% (0-200.0)% (0-3600)s	1 120.0 118.0 3	0: Disable; 1: Enable Set value is gen rated voltage percentage; Return value is gen rated voltage percentage;



No.	Items	Parameters	Defaults	Description
		(0-5)	5	Delay value Action
12.	Over Volt 2	(0-1) (0-200.0)% (0-200.0)% (0-3600)s (0-5)	1 110.0 108.0 5 1	0: Disable; 1: Enable Set value is gen rated voltage percentage; Return value is gen rated voltage percentage; Delay value Action
13.	Under Volt 1	(0-1) (0-200.0)% (0-200.0)% (0-3600)s (0-5)	1 80.0 82.0 3 5	0: Disable; 1: Enable Set value is gen rated voltage percentage; Return value is gen rated voltage percentage; Delay value Action
14.	Under Volt 2	(0-1) (0-200.0)% (0-200.0)% (0-3600)s (0-5)	1 84.0 86.0 5 1	0: Disable; 1: Enable Set value is gen rated voltage percentage; Return value is gen rated voltage percentage; Delay value Action
15.	Volt Unbalance 1	(0-1) (0-200.0)% (0-200.0)% (0-3600)s (0-5)	1 10.0 5.0 5 1	0: Disable 1: Enable Set value is degree of unbalance of gen voltage. Return value is degree of unbalance of gen voltage. Delay value Action
16.	Volt Unbalance 2	(0-1) (0-200.0)% (0-200.0)% (0-3600)s (0-5)	0 10.0 5.0 5 0	0: Disable 1: Enable Set value is gen degree of unbalance. Return value is gen degree of unbalance. Delay value Action
17.	THD Alarm 1	(0-1) (0-200.0)% (0-200.0)% (0-3600)s (0-5)	0 10.0 5.0 5 0	0: Disable 1: Enable Set value is degree of distortion of gen voltage. Return value is degree of distortion of gen voltage. Delay value Action
18.	THD Alarm 2	(0-1) (0-200.0)% (0-200.0)% (0-3600)s	0 10.0 5.0 5	0: Disable 1: Enable Set value is degree of distortion of gen voltage. Return value is degree of distortion of gen



No.	Items	Parameters	Defaults	Description
		(0-5)	0	voltage. Delay value Action
19.	Over Freq 1	(0-1) (0-200.0)% (0-200.0)% (0-3600)s (0-5)	1 114.0 112.0 2 5	0: Disable 1: Enable Set value is gen rated frequency percentage. Return value is gen rated frequency percentage. Delay value Action
20.	Over Freq 2	(0-1) (0-200.0)% (0-200.0)% (0-3600)s (0-5)	1 110.0 108.0 5 1	0: Disable 1: Enable Set value is gen rated frequency percentage. Return value is gen rated frequency percentage. Delay value Action
21.	Under Freq 1	(0-1) (0-200.0)% (0-200.0)% (0-3600)s (0-5)	1 80.0 82.0 3 5	0: Disable 1: Enable Set value is gen rated frequency percentage. Return value is gen rated frequency percentage. Delay value Action
22.	Under Freq 2	(0-1) (0-200.0)% (0-200.0)% (0-3600)s (0-5)	1 84.0 86.0 5 1	0: Disable 1: Enable Set value is gen rated frequency percentage. Return value is gen rated frequency percentage. Delay value Action
<b>Load Setting</b>				
1.	CT	(5-6000)/5	500	Ratio of external connected current transformer.
2.	Rated Current	(5-6000)A	500	It is rated current of generator and used for loading current standard.
3.	CT Position	(0-1)	0	0: Load; 1: Gen
4.	Over Current 1	(0-1) (0-200.0)% (0-200.0)% (0-3600)s (0-5)	1 120.0 118.0 3 4	0: Disable 1: Enable Set value is percentage of rated current. Return value is percentage of rated current. Delay value Action
5.	Over Current 2	(0-1)	1	0: Disable 1: Enable





No.	Items	Parameters	Defaults	Description
		(0-200.0)% (0-200.0)% (0-3600)s (0-5)	110.0 108.0 5 1	Set value is percentage of rated current. Return value is percentage of rated current. Delay value Action
6.	NegSeq Current 1	(0-1) (0-200.0)% (0-200.0)% (0-3600)s (0-5)	1 20.0 18.0 5 1	0: Disable 1: Enable Set value is percentage of rated current. Return value is percentage of rated current. Delay value Action
7.	NegSeq Current 2	(0-1) (0-200.0)% (0-200.0)% (0-3600)s (0-5)	0 20.0 18.0 5 0	0: Disable 1: Enable Set value is percentage of rated current. Return value is percentage of rated current. Delay value Action
8.	Earth Fault 1	(0-1) (0-200.0)% (0-200.0)% (0-3600)s (0-5)	1 20.0 18.0 5 1	0: Disable 1: Enable Set value is percentage of rated current. Return value is percentage of rated current. Delay value Action
9.	Earth Fault 2	(0-1) (0-200.0)% (0-200.0)% (0-3600)s (0-5)	0 20.0 18.0 5 0	0: Disable 1: Enable Set value is percentage of rated current. Return value is percentage of rated current. Delay value Action
10.	Rated Power(W)	(0-6000)kW	276	Genset rated active power, which is standard of loading active power.
11.	Rated Power(var)	(0-6000)kvar	210	Genset rated reactive power, which is standard of loading reactive power.
12.	Reverse Power 1	(0-1) (0-200.0)% (0-200.0)% (0-3600)s (0-5)	1 10.0 8.0 3 5	0: Disable 1: Enable Set value is percentage of rated active power. Return value is percentage of rated active power. Delay value Action
13.	Reverse Power 2	(0-1) (0-200.0)% (0-200.0)% (0-3600)s (0-5)	1 5.0 3.0 5 1	0: Disable 1: Enable Set value is percentage of rated active power. Return value is percentage of rated active power. Delay value Action
14.	Over Power 1	(0-1)	1	0: Disable 1: Enable



No.	Items	Parameters	Defaults	Description
		(0-200.0)% (0-200.0)% (0-3600)s (0-5)	120.0 118.0 3 5	Set value is percentage of rated active power. Return value is percentage of rated active power. Delay value Action
15.	Over Power 2	(0-1) (0-200.0)% (0-200.0)% (0-3600)s (0-5)	1 110.0 108.0 5 1	0: Disable    1: Enable Set value is percentage of rated active power. Return value is percentage of rated active power. Delay value Action
16.	Loss Excition 1	(0-1) (0-200.0)% (0-200.0)% (0-3600)s (0-5)	1 20.0 18.0 5 1	0: Disable    1: Enable Set value is percentage of rated inactive power. Return value is percentage of rated inactive power. Delay value Action
17.	Loss Excition 2	(0-1) (0-200.0)% (0-200.0)% (0-3600)s (0-5)	0 20.0 18.0 5 0	0: Disable    1: Enable Set value is percentage of rated inactive power. Return value is percentage of rated inactive power. Delay value Action
18.	PF Low 1	(0-1) (0-1.00) (0-1.00) (0-3600)s (0-5)	1 0.70 0.75 5 1	0: Disable    1: Enable Set value is gen power factor. Return value is gen power factor. Delay value Action
19.	PF Low 2	(0-1) (0-1.00) (0-1.00) (0-3600)s (0-5)	0 0.70 0.75 5 0	0: Disable    1: Enable Set value is gen power factor. Return value is gen power factor. Delay value Action
<b>Switch Setting</b>				
1.	Close Time	(0-20.0)s	5.0	Pulse width of switch on. When it is 0, it means output constantly.
2.	Open Time	(0-20.0)s	3.0	Pulse width of switch off.
3.	Check Time	(0-20.0)s	5.0	After ATS transfer, check time for switch auxiliary contact.



No.	Items	Parameters	Defaults	Description
4.	Open Check Enable	(0-1)	0	0: Disable; 1: Enable
5.	Check Fail Warn	(0-1)	0	Interval time from Mains open to Gen close or from Gen open to Mains close;
6.	Transfer Time	(0-7200)s	5	
7.	Mains Abnormal Trip	(0-1)	1	0: Disable; 1: Enable
<b>Analog Sensor Setting</b>				
<b>Temperature Sensor</b>				
1.	Curve Type	(0~15)	8	SGD; For details please see Table 16.
2.	Open Act	(0-5)	1	0: None; 1: Warning; 2: Block; 3: Trip; 4: Trip and Stop; 5: Shutdown.
3.	Over Alarm 1	(0-1)	1	0: Disable 1: Enable
		((-50)-300)°C	98	Set value is engine temperature value.
		((-50)-300)°C	96	Set value is engine temperature value.
		(0-3600)s	3	Delay value
(0-5)	5	Action		
4.	Over Alarm 2	(0-1)	1	0: Disable 1: Enable
		((-50)-300)°C	95	Set value is engine temperature value.
		((-50)-300)°C	93	Set value is engine temperature value.
		(0-3600)s	5	Delay value
(0-5)	1	Action		
5.	Under Alarm	(0-1)	0	0: Disable 1: Enable
		((-50)-300)°C	70	Set value is engine temperature value.
		((-50)-300)°C	75	Set value is engine temperature value.
		(0-3600)s	5	Delay value
(0-5)	1	Action		
6.	Custom Curve			
<b>Oil Pressure Sensor</b>				
1.	Curve Type	(0~15)	8	SGD; For details please see Table 16.
2.	Open Act	(0~5)	1	0: None; 1: Warning; 2: Block; 3: Trip; 4: Trip and Stop; 5: Shutdown.
3.	Under Alarm 1	(0-1)	1	0: Disable 1: Enable
		(0-1000)kPa	103	Set value is engine oil pressure value.
		(0-1000)kPa	117	Set value is engine oil pressure value.
		(0-3600)s	2	Delay value
(0-5)	5	Action		
4.	Under Alarm 2	(0-1)	1	0: Disable 1: Enable
		(0-1000)kPa	124	Set value is engine oil pressure value.
		(0-1000)kPa	138	Set value is engine oil pressure value.
		(0-3600)s	5	Delay value
(0-5)	1	Action		
5.	Custom Curve			
<b>Fuel Level Sensor</b>				
1.	Curve Type	(0~15)	4	SGD; For details please see Table 16.



No.	Items	Parameters	Defaults	Description
2.	Open Act	(0-5)	0	0: None; 1: Warning; 2: Block; 3: Trip; 4: Trip and Stop; 5: Shutdown.
3.	Under Alarm 1	(0-1)	1	0: Disable 1: Enable
		(0-100)%	0	Set value is engine fuel level value.
		(0-100)%	5	Set value is engine fuel level value.
		(0-3600)s	5	Delay value
4.	Under Alarm 2	(0-1)	1	0: Disable 1: Enable
		(0-100)%	10	Set value is engine fuel level value.
		(0-100)%	15	Set value is engine fuel level value.
		(0-3600)s	5	Delay value
5.	Custom Curve	(0-5)	5	Action
		(0-5)	5	Action
6.	Fuel Usage	(0-1) (0-10000)L	0 1000	0: Disable 1: Enable Engine oil volume value.
7.	Fuel Economy En	(0-1)	0	0: Disable 1: Enable
8.	Fuel Economy Curve			
<b>Flexible Sensor 1</b>				
1.	Sensor Type	(0-3)	0	0: None 1: Tempe Sensor 2: Pressure Sensor 3: Level Sensor
<b>Flexible Sensor 2</b>				
1.	Sensor Type	(0-3)	0	0: None 1: Tempe Sensor 2: Pressure Sensor 3: Level Sensor
<b>Flexible Sensor 3</b>				
1.	Sensor Type	(0-3)	0	0: None 1: Tempe Sensor 2: Pressure Sensor 3: Level Sensor
<b>Digital Input Ports</b>				
<b>Digital Input Port 1</b>				
1.	Contents Setting	(0~70)	28	Remote start (on demand). For details see Table 15.
2.	Active Type	(0~1)	0	0: Close 1: Open
<b>Digital Input Port 2</b>				
1.	Contents Setting	(0~70)	26	Temperature high shutdown input. For details see Table 15.
2.	Active Type	(0~1)	0	0: Close 1: Open

No.	Items	Parameters	Defaults	Description
<b>Digital Input Port 3</b>				
1.	Contents Setting	(0~70)	27	Low oil pressure shutdown input; For details see Table 15.
2.	Active Type	(0~1)	0	0: Close 1: Open
<b>Digital Input Port 4</b>				
1.	Contents Setting	(0~70)	0	User defined. For details see Table 15.
2.	Active Type	(0~1)	0	0: Close 1: Open
3.	Arming	(0-3)	2	0: From safety on 1: From starting 2: Always 3: Never
4.	Action	(0-5)	0	0: None; 1: Warning; 2: Block; 3: Trip; 4: Trip Shutdown; 5: Shutdown
5.	Delay	(0-20.0)s	2.0	Time from detecting input port is active to confirm;
6.	Input Port Description			When input port is active, LCD displays the contents.
<b>Digital Input Port 5</b>				
1.	Contents Setting	(0-70)	0	Users-defined; For details see Table 15.
2.	Active Type	(0-1)	0	0: Close 1: Open
3.	Arming	(0-3)	2	0: From safety on 1: From starting 2: Always 3: Never
4.	Active Actions	(0-5)	1	0: None; 1: Warning; 2: Block; 3: Trip; 4: Trip Shutdown; 5: Shutdown
5.	Active Delay	(0-20.0)s	2.0	Time from detecting active to confirm
6.	Description			LCD displays detailed contents when the input is active.
<b>Digital Input Port 6</b>				
1.	Contents Setting	(0-70)	0	Users-defined; For details see Table 15.
2.	Active Type	(0-1)	0	0: Close 1: Open
3.	Arming	(0-3)	2	0: From safety on 1: From starting 2: Always 3: Never
4.	Active Actions	(0-5)	2	0: None; 1: Warning; 2: Block; 3: Trip; 4: Trip Shutdown; 5: Shutdown
5.	Active Delay	(0-20.0)s	2.0	Time from detecting active to confirm
6.	Description			LCD displays detailed contents when the input is active.
<b>Digital Input Port 7</b>				
1.	Contents Setting	(0~70)	5	Lamp test; For details see Table 15.
2.	Active Type	(0~1)	0	0: Close 1: Open
<b>Digital Input Port 8</b>				
1.	Contents Setting	(0-70)	0	User defined. For details see Table 15.
2.	Active Type	(0-1)	0	0: Close 1: Open
3.	Arming	(0-3)	0	0: From safety on 1: From starting



No.	Items	Parameters	Defaults	Description
				2: Always 3: Never
4.	Active Actions	(0-5)	0	0: None; 1: Warning; 2: Block; 3: Trip; 4: Trip Shutdown; 5: Shutdown
5.	Active Delay	(0-20.0)s	2.0	Time from detecting active to confirm.
6.	Description			LCD displays detailed contents when the input is active.
<b>Digital Input Port 9</b>				
1.	Contents Setting	(0-70)	0	Users-defined. For details see Table 15.
2.	Active Type	(0-1)	0	0: Close 1: Open
3.	Arming	(0-3)	0	0: From safety on 1: From starting 2: Always 3: Never
4.	Active Actions	(0-5)	0	0: None; 1: Warning; 2: Block; 3: Trip; 4: Trip Shutdown; 5: Shutdown
5.	Active Delay	(0-20.0)s	2.0	Time from detecting active to confirm
6.	Description			LCD displays detailed contents when the input is active.
<b>Digital Input Port 10</b>				
1.	Contents Setting	(0-70)	0	Users-defined. For details see Table 15.
2.	Active Type	(0-1)	0	0: Close 1: Open
3.	Arming	(0-3)	0	0: From safety on 1: From starting 2: Always 3: Never
4.	Active Actions	(0-5)	0	0: None; 1: Warning; 2: Block; 3: Trip; 4: Trip Shutdown; 5: Shutdown
5.	Active Delay	(0-20.0)s	2.0	Time from detecting active to confirm
6.	Description			LCD displays detailed contents when the input is active.
<b>Digital Output Ports</b>				
<b>Digital Output Port 1</b>				
1	Contents Setting	(0-299)	35	Idle speed control; For details please see Table 14.
2	Active Type	(0-1)	0	0: Normally open; 1: Normally close
<b>Digital Output Port 2</b>				
1	Contents Setting	(0~299)	48	Common Alarm; For details please see Table 14.
2	Active Type	(0~1)	0	0: Normally open; 1: Normally close
<b>Digital Output Port 3</b>				
1	Contents Setting	(0~299)	38	Energise to Stop; For details please see Table 14.
2	Active Type	(0~1)	0	0: Normally open; 1: Normally close
<b>Digital Output Port 4</b>				
1	Contents Setting	(0~299)	31	Mains close output; For details please see Table 14.





No.	Items	Parameters	Defaults	Description
2	Active Type	(0~1)	0	0: Normally open; 1: Normally close
<b>Digital Output Port 5</b>				
1	Contents Setting	(0~299)	28	Open output; For details please see Table 14.
2	Active Type	(0~1)	0	0: Normally open; 1: Normally close
<b>Digital Output Port 6</b>				
1	Contents Setting	(0~299)	29	Gen close output; For details please see Table 14.
2	Active Type	(0~1)	0	0: Normally open; 1: Normally close
<b>Digital Output Port 7</b>				
1	Contents Setting	(0~299)	0	Not Used; For details please see Table 14.
2	Active Type	(0~1)	0	0: Normally open; 1: Normally close
<b>Digital Output Port 8</b>				
1	Contents Setting	(0~299)	0	Not Used; For details please see Table 14.
2	Active Type	(0~1)	0	0: Normally open; 1: Normally close
<b>Digital Output Port 9</b>				
1	Contents Setting	(0-299)	0	Not Used; For details please see Table 14.
2	Active Type	(0-1)	0	0: Normally open; 1: Normally close
<b>Digital Output Port 10</b>				
1	Contents Setting	(0-299)	0	Not Used; For details please see Table 14.
2	Active Type	(0-1)	0	0: Normally open; 1: Normally close
<b>Scheduled Run</b>				
1	Scheduled Run	(0~1)	0	0: Disable; 1: Enable Circular setting (monthly, weekly, daily), start time setting, continuous time setting and loading selection are available.
<b>Scheduled Not Run</b>				
1	Scheduled Not Run	(0~1)	0	0: Disable; 1: Enable Circular setting (monthly, weekly, daily), non-start time setting, continuous time setting are available.
<b>Maintenance Setting</b>				
<b>Maintenance 1 Setting</b>				
1	Maintenance	(0-1)	0	0: Disable; 1: Enable Maintenance countdown, time due action, pre-alarm time of A and B and action can be set.
<b>Maintenance 2 Setting</b>				
1	Maintenance	(0-1)	0	0: Disable; 1: Enable Maintenance countdown, time due action, pre-alarm time of A and B and action can be set.



No.	Items	Parameters	Defaults	Description
<b>Maintenance 3 Setting</b>				
1	Maintenance	(0-1)	0	0: Disable; 1: Enable Maintenance countdown, time due action, pre-alarm time of A and B and action can be set.
<b>Alternative Configuration</b>				
<b>Alt. Config. 1</b>				
1	Enable	(0-1)	0	0: Disable; 1: Enable Power supply system, rated voltage, rated frequency, rated speed, rated current, rated active power, rated reactive power can be set.
<b>Alt. Config. 2</b>				
2	Enable	(0-1)	0	0: Disable; 1: Enable Power supply system, rated voltage, rated frequency, rated speed, rated current, rated active power, rated reactive power can be set.
<b>Alt. Config. 3</b>				
3	Enable	(0-1)	0	0: Disable; 1: Enable Power supply system, rated voltage, rated frequency, rated speed, rated current, rated active power, rated reactive power can be set.
<b>Sync Setting</b>				
<b>Auto Sync</b>				
1	Check Enable	(0-1)	0	0: Disable; 1: Enable
2	Check Volt	(0-30)V	3	Voltage difference of Gen and Mains; if it is below sync volt difference, then volt sync is considered.
3	Check Pos Freq	(0-2.00)Hz	0.20	Freq difference of Gen and Mains; if it is below positive difference of sync, and above negative difference of sync, freq sync is considered.
4	Check Neg Freq	(0-2.00)Hz	0.10	
5	Check Phase Ang	(0-20)°	10	Primary phase difference of Gen and Mains, if it is below phase angle difference of sync, phase sync is considered.
6	Fail Sync Act	(0-5)	0	0: None; 1: Warning; 2: Block; 3: Trip; 4: Trip Stop; 5: Shutdown
7	Fail Sync Delay	(0-3600)s	120	Maximum waiting sync time; if time is due, but it still doesn't meet sync condition, then alarm is issued.
8	Fail Transl. Time	(0.1-1.0)s	0.6	At sync transferring, sync close or open



No.	Items	Parameters	Defaults	Description
				output delay starts; during the delay if correct close/open status is detected, then close/open pulse output is stopped; if after the delay correct status still is not detected, then alarm is issued; NOTE: if sync close/open detection time is smaller than close/open time, then sync close/open time is switch close/open time.
9	Fail Close Enable	(0-1)	0	0: Disable 1: Enable
<b>NEL Settings</b>				
1.	Number	(1-3)	3	Details of function description please see the following description.
2.	Auto Trip	(0-1)	0	
3.	Auto Trip 1 Set Value	(0-200)%	90	
4.	Auto Trip 1 Delay	(0-3600)s	5	
5.	Auto Trip 2 Set Value	(0-200)%	100	
6.	Auto Trip 2 Delay	(0-3600)s	1	
7.	Auto Reconnection	(0-1)	0	
8.	Auto Reconnection Set Value	(0-200)%	50	
9.	Auto Reconnection Delay	(0-3600)s	5	
<b>Dummy Load</b>				
1.	Number	(1-3)	3	Details of function description please see the following description.
2.	Connection	(0-1)	0	
3.	Connection Value 1	(0-200)%	20	
4.	Connection Delay 1	(0-3600)s	5	
5.	Connection Value 2	(0-200)%	10	
6.	Connection Delay 2	(0-3600)s	1	
7.	Auto Trip	(0-1)	0	
8.	Trip Value	(0-200)%	50	
9.	Trip Delay	(0-3600)s	5	
<b>Expansion Module</b>				
1.	Exp DIN16	(0-1)	0	0: Disable ; 1: Enable
2.	Exp DOUT16	(0-1)	0	0: Disable ; 1: Enable
3.	Exp AIN24 1	(0-1)	0	0: Disable ; 1: Enable
4.	Exp AIN24 2	(0-1)	0	0: Disable ; 1: Enable
5.	Exp AIN16-M02 1	(0-1)	0	0: Disable ; 1: Enable
6.	Exp AIN16-M02 2	(0-1)	0	0: Disable ; 1: Enable
7.	Exp AIN8	(0-1)	0	0: Disable ; 1: Enable



No.	Items	Parameters	Defaults	Description
8.	SGE02-4G	(0-1)	0	0: Disable ; 1: Enable
9.	BAC150CAN	(0-1)	0	0: Disable ; 1: Enable

SmartGen

## 8.2 ENABLE DEFINITION OF PROGRAMMABLE OUTPUT PORTS

### 8.2.1 DEFINITION OF DIGITAL OUTPUT PORTS

**Table 14 Definition of Digital Output Ports**

No.	Type	Description
0	Not Used	
1	Custom Period 1	Details of function description please see the following description.
2	Custom Period 2	
3	Custom Period 3	
4	Custom Period 4	
5	Custom Period 5	
6	Custom Period 6	
7	Custom Combined 1	
8	Custom Combined 2	
9	Custom Combined 3	
10	Custom Combined 4	
11	Custom Combined 5	
12	Custom Combined 6	
13	Reserved	
14	Reserved	
15	Gas Choke On	
16	Gas Ignition	
17	Air Flap Control	Act on over speed shutdown and emergence stop. Air inflow can be closed.
18	Audible Alarm	Act on warning, block, trip, trip and stop, and shutdown. An annunciator can be connected externally. If 'alarm mute' configurable input port is active, this is prohibited.
19	Louver Control	Act when genset is starting and disconnect when genset is stopped completely.
20	Fuel Pump Control	It is controlled by limit values of level sensor fuel pump.
21	Heater Control	It is controlled by heating limit values of temperature sensor.
22	Cooler Control	It is controlled by cooler limit values of temperature sensor.
23	Pre-fuel	Act in the period from 'cranking' to 'safety on'.
24	Generator Excite	Output in start process. If there is not generator frequency during hi-speed running, it shall output for 2 seconds again.
25	Pre-lubricate	Act from pre-heating to safety on.
26	Remote Control	This port is controlled by communication (PC).
27	Reserved	
28	Open Breaker	Control breaker offload when sync. transfer is not enabled.
29	Close Gen Output	It can control generating switch to take load.
30	Open Gen Breaker	It can control generating switch to take off load when sync. transfer is enabled.



No.	Type	Description
31	Close Mains Output	It can control mains switch to take load.
32	Open Mains Breaker	It can control mains switch to take off load when sync. transfer is enabled.
33	Start Relay	
34	Fuel Relay	Act when genset is starting and disconnect when stop is completed. When gas timer is enabled, fuel relay output is used to control gas valve.
35	Idle Control	It is used for engine with idling control. Close before starting and open in warming up delay; Close during stopping idle mode and open when stop is completed.
36	Speed Raise Relay	Act during warming up time.
37	Speed Drop Relay	Act between the period 'stop idle' and 'failed to stop'.
38	Energize to Stop	It is used for engines with ETS electromagnet. Close when stop idle is over and open when pre-set 'ETS delay' is over.
39	Speed Drop Pulse	Act for 0.1s when controller enters 'stop idle', used for control parts of ECU dropping to idle speed.
40	ECU Stop	Used for ECU engine to control its stop.
41	ECU Power Supply	Used for ECU engine to control its power.
42	Speed Raise Pulse	Act for 0.1s when controller enters warming up delay; used for control parts of ECU raising to normal speed.
43	Crank Success	Close when a successful start signal is detected.
44	Generator OK	Act when generator is normally running.
45	Generator Available	Act between normal running and hi-speed cooling.
46	Mains OK	Act when mains is normal.
47	Reserved	Act when controller is synchronizing.
48	Common Alarm	Act when genset common warning, common shutdown, common trip, common trip and stop, common block alarms occur.
49	Common Trip and Stop	Act when common trip and stop alarm occurs.
50	Common Shutdown	Act when common shutdown alarm occurs.
51	Common Trip	Act when common trip alarm occurs.
52	Common Warning	Act when common warning alarm occurs.
53	Common Block	Act when common block alarm occurs.
54	Battery Over Voltage	Act when battery's over voltage warning alarm occurs.
55	Battery Under Voltage	Act when battery's low voltage warning alarm occurs.
56	Charge Alternator Failure	Act when charging failure warning alarm occurs.
57	Reserved	
58	Reserved	
59	Reserved	
60	ECU Warning	Indicates ECU sends a warning signal.
61	ECU Shutdown	Indicates ECU sends a shutdown signal.





No.	Type	Description
62	ECU Com Fail	Indicates controller is not communicating with ECU.
63	Reserved	
64	Reserved	
65	Reserved	
66	Reserved	
67	Reserved	
68	Reserved	
69	Input 1 Active	Act when input port 1 is active.
70	Input 2 Active	Act when input port 2 is active.
71	Input 3 Active	Act when input port 3 is active.
72	Input 4 Active	Act when input port 4 is active.
73	Input 5 Active	Act when input port 5 is active.
74	Input 6 Active	Act when input port 6 is active.
75	Input 7 Active	Act when input port 7 is active.
76	Input 8 Active	Act when input port 8 is active.
77	Input 9 Active	Act when input port 9 is active.
78	Input 10 Active	Act when input port 10 is active.
79	Reserved	
80	Reserved	
81	Exp DI Input 1 Active	Act when expansion module DIN16 input 1 is active.
82	Exp DI Input 2 Active	Act when expansion module DIN16 input 2 is active.
83	Exp DI Input 3 Active	Act when expansion module DIN16 input 3 is active.
84	Exp DI Input 4 Active	Act when expansion module DIN16 input 4 is active.
85	Exp DI Input 5 Active	Act when expansion module DIN16 input 5 is active.
86	Exp DI Input 6 Active	Act when expansion module DIN16 input 6 is active.
87	Exp DI Input 7 Active	Act when expansion module DIN16 input 7 is active.
88	Exp DI Input 8 Active	Act when expansion module DIN16 input 8 is active.
89	Exp DI Input 9 Active	Act when expansion module DIN16 input 9 is active.
90	Exp DI Input 10 Active	Act when expansion module DIN16 input 10 is active.
91	Exp DI Input 11 Active	Act when expansion module DIN16 input 11 is active.
92	Exp DI Input 12 Active	Act when expansion module DIN16 input 12 is active.
93	Exp DI Input 13 Active	Act when expansion module DIN16 input 13 is active.
94	Exp DI Input 14 Active	Act when expansion module DIN16 input 14 is active.
95	Exp DI Input 15 Active	Act when expansion module DIN16 input 15 is active.
96	Exp DI Input 16 Active	Act when expansion module DIN16 input 16 is active.
97	Reserved	
98	Reserved	
99	Emergency Stop	Act when emergency stop alarm occurs.
100	Fail To Start	Act when start failure alarm occurs.
101	Fail To Stop	Act when stop failure alarm occurs.
102	Under Speed Warn	Act when under speed alarm occurs.
103	Under Speed Alarm	Act when under speed alarm (except warning) occurs.



No.	Type	Description
104	Over Speed Warn	Act when over speed warning occurs.
105	Over Speed Alarm	Act when over speed alarm (except warning) occurs.
106	Reserved	
107	Reserved	
108	Reserved	
109	Gen Over Freq. Warn	Act when generator over frequency warning occurs.
110	Gen Over Freq. Alarm	Act when generator over frequency alarm (except warning) occurs.
111	Gen Over Volt Warn	Act when generator over voltage warning occurs.
112	Gen Over Volt Alarm	Act when generator over voltage alarm (except warning) occurs.
113	Gen Under Freq. Warn	Act when generator low frequency warning occurs.
114	Gen Under Freq. Alarm	Act when generator low frequency alarm (except warning) occurs.
115	Gen Under Volt. Warn	Act when generator low voltage warning occurs.
116	Gen Under Volt. Alarm	Act when generator low voltage alarm (except warning) occurs.
117	Gen Loss of Phase	Act when generator loss of phase occurs.
118	Gen Phase Sequence Wrong	Act when generator reverse phase sequence occurs.
119	Over Power Warn	Act when gen over power warning occurs.
120	Over Power Alarm	Act (except warning) when over power warning occurs.
121	Reverse Power Warn	Act when gen reverse power warning occurs.
122	Reverse Power Alarm	Act (except warning) when controller detects generator reverse power.
123	Over Current Warn	Act when over current warning occurs.
124	Over Current Alarm	Act when gen over current alarm (except warning) occurs.
125	Mains Inactive	
126	Mains Over Freq	
127	Mains Over Volt	
128	Mains Under Freq	
129	Mains Under Volt	
130	Mains Phase Seq Wrong	
131	Mains Loss Phase	
132	Reserved	
133	Reserved	
134	NEL1 Trip	
135	NEL2 Trip	
136	NEL3 Trip	
137	Reserved	
138	Reserved	
139	High Temp Warn	Act when hi-temperature warning occurs.
140	Low Temp Warn	Act when low temperature warning occurs.



No.	Type	Description
141	High Temp Alarm	Act when hi-temperature alarm (except warning) occurs.
142	Reserved	
143	Low OP Warn	Act when low oil pressure warning occurs.
144	Low OP Alarm	Act when low oil pressure alarm (except warning) occurs.
145	OP Sensor Open	Act when oil pressure sensor is open circuit.
146	Reserved	
147	Low FL Warn	Act when controller has low fuel level warning alarm.
148	Low FL Alarm	Act when controller has low fuel level alarm (except warning).
149	Reserved	
150	Flex 1 High Warn	Act when controller has flexible sensor 1 high warning alarm.
151	Flex 1 Low Warn	Act when controller has flexible sensor 1 low warning alarm.
152	Flex 1 High Alarm	Act when controller has flexible sensor 1 high alarm (except warning).
153	Flex 1 Low Alarm	Act when controller has flexible sensor 1 low alarm (except warning).
154	Flex 2 High Warn	Act when controller has flexible sensor 2 high warning alarm.
155	Flex 2 Low Warn	Act when controller has flexible sensor 2 low warning alarm.
156	Flex 2 High Alarm	Act when controller has flexible sensor 2 high alarm (except warning).
157	Flex 2 Low Alarm	Act when controller has flexible sensor 2 low alarm (except warning).
158	Flex 3 High Warn	Act when controller has flexible sensor 3 high warning alarm.
159	Flex 3 Low Warn	Act when controller has flexible sensor 3 low warning alarm.
160	Flex 3 High Alarm	Act when controller has flexible sensor 3 high alarm (except warning).
161	Flex 3 Low Alarm	Act when controller has flexible sensor 3 low alarm (except warning).
162	Exp1Ch15 High Alarm	Act when expansion AIN24 1 sensor 15 high alarm (except warning) occurs.
163	Exp1 Ch15 High Warn	Act when expansion AIN24 1 sensor 15 high warning occurs.
164	Exp1 Ch15 Low Alarm	Act when expansion AIN24 1 sensor 15 low alarm (except warning) occurs.
165	Exp1 Ch15 Low Warn	Act when expansion AIN24 1 sensor 15 low warning occurs.
166	Exp1 Ch16 High Alarm	Act when expansion AIN24 1 sensor 16 high alarm (except warning) occurs.
167	Exp1 Ch16 High Warn	Act when expansion AIN24 1 sensor 16 high warning occurs.
168	Exp1 Ch16 Low Alarm	Act when expansion AIN24 1 sensor 16 low alarm (except warning) occurs.
169	Exp1 Ch16 Low Warn	Act when expansion AIN24 1 sensor 16 low warning occurs.
170	Exp1 Ch17 High Alarm	Act when expansion AIN24 1 sensor 17 high alarm (except warning) occurs.
171	Exp1 Ch17 High Warn	Act when expansion AIN24 1 sensor 17 high warning occurs.



No.	Type	Description
172	Exp1 Ch17 Low Alarm	Act when expansion AIN24 1 sensor 17 low alarm (except warning) occurs.
173	Exp1 Ch17 Low Warn	Act when expansion AIN24 1 sensor 17 low warning occurs.
174	Exp1 Ch18 High Alarm	Act when expansion AIN24 1 sensor 18 high alarm (except warning) occurs.
175	Exp1 Ch18 High Warn	Act when expansion AIN24 1 sensor 18 high warning occurs.
176	Exp1 Ch18 Low Alarm	Act when expansion AIN24 1 sensor 18 low alarm (except warning) occurs.
177	Exp1 Ch18 Low Warn	Act when expansion AIN24 1 sensor 18 low warning occurs.
178	Exp1 Ch19 High Alarm	Act when expansion AIN24 1 sensor 19 high alarm (except warning) occurs.
179	Exp1 Ch19 High Warn	Act when expansion AIN24 1 sensor 19 high warning occurs.
180	Exp1 Ch19 Low Alarm	Act when expansion AIN24 1 sensor 19 low alarm (except warning) occurs.
181	Exp1 Ch19 Low Warn	Act when expansion AIN24 1 sensor 19 low warning occurs.
182	Exp1 Ch20 High Alarm	Act when expansion AIN24 1 sensor 20 high alarm (except warning) occurs.
183	Exp1 Ch20 High Warn	Act when expansion AIN24 1 sensor 20 high warning occurs.
184	Exp1 Ch20 Low Alarm	Act when expansion AIN24 1 sensor 20 low alarm (except warning) occurs.
185	Exp1 Ch20 Low Warn	Act when expansion AIN24 1 sensor 20 low warning occurs.
186	Exp1 Ch21 High Alarm	Act when expansion AIN24 1 sensor 21 high alarm (except warning) occurs.
187	Exp1 Ch21 High Warn	Act when expansion AIN24 1 sensor 21 high warning occurs.
188	Exp1 Ch21 Low Alarm	Act when expansion AIN24 1 sensor 21 low alarm (except warning) occurs.
189	Exp1 Ch21 Low Warn	Act when expansion AIN24 1 sensor 21 low warning occurs.
190	Exp1 Ch22 High Alarm	Act when expansion AIN24 1 sensor 22 high alarm (except warning) occurs.
191	Exp1 Ch22 High Warn	Act when expansion AIN24 1 sensor 22 high warning occurs.
192	Exp1 Ch22 Low Alarm	Act when expansion AIN24 1 sensor 22 low alarm (except warning) occurs.
193	Exp1 Ch22 Low Warn	Act when expansion AIN24 1 sensor 22 low warning occurs.
194	Exp1 Ch23 High Alarm	Act when expansion AIN24 1 sensor 23 high alarm (except warning) occurs.
195	Exp1 Ch23 High Warn	Act when expansion AIN24 1 sensor 23 high warning occurs.
196	Exp1 Ch23 Low Alarm	Act when expansion AIN24 1 sensor 23 low alarm (except warning) occurs.
197	Exp1 Ch23 Low Warn	Act when expansion AIN24 1 sensor 23 low warning occurs.
198	Exp1 Ch24 High Alarm	Act when expansion AIN24 1 sensor 24 high alarm (except warning) occurs.
199	Exp1 Ch24 High Warn	Act when expansion AIN24 1 sensor 24 high warning occurs.



No.	Type	Description
200	Exp1 Ch24 Low Alarm	Act when expansion AIN24 1 sensor 24 low alarm (except warning) occurs.
201	Exp1 Ch24 Low Warn	Act when expansion AIN24 1 sensor 24 low warning occurs.
202	M02-1 Ch1 Low Warn	Act when expansion AIN16M02 Sensor 1 low warning occurs.
203	M02-1 Ch1 Low Alarm	Act when expansion AIN16M02 Sensor 1 low alarm (except warning) occurs.
204	M02-1 Ch1 High Warn	Act when expansion AIN16M02 Sensor 1 high warning occurs.
205	M02-1 Ch1 High Alarm	Act when expansion AIN16M02 Sensor 1 high alarm (except warning) occurs.
206	M02-1 Ch 2 Low Warn	Act when expansion AIN16M02 Sensor 2 low warning occurs.
207	M02-1 Ch 2 Low Alarm	Act when expansion AIN16M02 Sensor 2 low alarm (except warning) occurs.
208	M02-1 Ch 2 High Warn	Act when expansion AIN16M02 Sensor 2 high warning occurs.
209	M02-1 Ch 2 High Alarm	Act when expansion AIN16M02 Sensor 2 high alarm (except warning) occurs.
210	M02-1 Ch 3 Low Warn	Act when expansion AIN16M02 Sensor 3 low warning occurs.
211	M02-1 Ch 3 Low Alarm	Act when expansion AIN16M02 Sensor 3 low alarm (except warning) occurs.
212	M02-1 Ch 3 High Warn	Act when expansion AIN16M02 Sensor 3 high warning occurs.
213	M02-1 Ch 3 High Alarm	Act when expansion AIN16M02 Sensor 3 high alarm (except warning) occurs.
214	M02-1 Ch 4 Low Warn	Act when expansion AIN16M02 Sensor 4 low warning occurs.
215	M02-1 Ch 4 Low Alarm	Act when expansion AIN16M02 Sensor 4 low alarm (except warning) occurs.
216	M02-1 Ch 4 High Warn	Act when expansion AIN16M02 Sensor 4 high warning occurs.
217	M02-1 Ch 4 High Alarm	Act when expansion AIN16M02 Sensor 4 high alarm (except warning) occurs.
218	Reserved	
219	Reserved	
220	DL1 Connect	Details of function description please see the following description.
221	DL2 Connect	
222	DL3 Connect	
223-229	Reserved	
230	Stop Mode	Act when the system is in stop mode.
231	Manual Mode	Act when the system is in Manual mode.
232	Reserved	Reserved
233	Auto Mode	Act when the system is in Auto mode.
234	Generator Load	
235	Mains Load	
236	Reserved	
237	Reserved	
238	Reserved	





No.	Type	Description
239	Reserved	
240-279	PLC Flag1~40	PLC flag output.
280	AIN8 Ch1 Low Warn	Act when expansion AIN8 Sensor 1 low warning occurs.
281	AIN8 Ch1 Low Alarm	Act when expansion AIN8 Sensor 1 low alarm (except warning) occurs.
282	AIN8 Ch1 High Warn	Act when expansion AIN8 Sensor 1 high warning occurs.
283	AIN8 Ch1 High Alarm	Act when expansion AIN8 Sensor 1 high alarm (except warning) occurs.
284	AIN8 Ch 2 Low Warn	Act when expansion AIN8 Sensor 2 low warning occurs.
285	AIN8 Ch 2 Low Alarm	Act when expansion AIN8 Sensor 2 low alarm (except warning) occurs.
286	AIN8 Ch 2 High Warn	Act when expansion AIN8 Sensor 2 high warning occurs.
287	AIN8 Ch 2 High Alarm	Act when expansion AIN8 Sensor 2 high alarm (except warning) occurs.
288	AIN8 Ch 3 Low Warn	Act when expansion AIN8 Sensor 3 low warning occurs.
289	AIN8 Ch 3 Low Alarm	Act when expansion AIN8 Sensor 3 low alarm (except warning) occurs.
290	AIN8 Ch 3 High Warn	Act when expansion AIN8 Sensor 3 high warning occurs.
291	AIN8 Ch 3 High Alarm	Act when expansion AIN8 Sensor 3 high alarm (except warning) occurs.
292	AIN8 Ch 4 Low Warn	Act when expansion AIN8 Sensor 4 low warning occurs.
293	AIN8 Ch 4 Low Alarm	Act when expansion AIN8 Sensor 4 low alarm (except warning) occurs.
294	AIN8 Ch 4 High Warn	Act when expansion AIN8 Sensor 4 high warning occurs.
295	AIN8 Ch 4 High Alarm	Act when expansion AIN8 Sensor 4 high alarm (except warning) occurs.
296-299	Reserved	



### 8.2.2 DEFINED PERIOD OUTPUT

Defined Period output is composed by 2 parts, **period output S1** and **condition output S2**.



While **S1** and **S2** are **TRUE** synchronously, **OUTPUT**;

While **S1** or **S2** is **FALSE**, **NOT OUTPUT**.

**Period output S1** can set generator's one or more period outputs freely, can set the delayed time and output time after entering into period.

**Condition output S2** can set as any conditions in output ports.

**▲NOTE 1:** when delay time and output time both are 0 in period output S1, it is **TRUE** in this period.

**▲NOTE 1:** when selected period is standby, it is cycle output, and other periods are single output.

For example:

Output period: start

Delay output time: 2s

Output time: 3s

Condition output contents: output port 1 is active

Close when condition output active/inactive: close when active (disconnect when inactive);

Output port 1 active, after enter "starts time" and delay 2s, this defined period output is outputting, after 3s, stop outputting;

Output port 1 inactive, defined output period is not outputting.

### 8.2.3 DEFINED COMBINATION OUTPUT

Defined combination output is composed by 3 parts, **or condition output S1**, **or condition output S2** and **and condition output S3**.

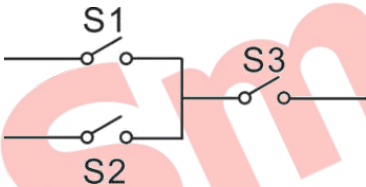

**S1** or **S2** is **TRUE**, while **S3** is **TRUE**, defined combination output is outputting;

**S1** and **S2** are **FALSE**, or **S3** is **FALSE**, defined combination output is not outputting.

**▲NOTE:** S1, S2, S3 can be set as any contents except for "defined combination output" itself in the output setting.

**▲NOTE:** 3 parts of defined combination output (S1, S2, S3) couldn't include or recursively include themselves.

For example:

Contents of or condition output S1: output port 1 is active;

Close when or condition output S1 is active /inactive: close when active (disconnect when inactive);

Contents of or condition output S2, output port 2 is active;

Close when or condition output S2 is active /inactive: close when active (disconnect when inactive);

Contents of or condition output S3: output port 3 is active;

Close when or condition output S3 is active /inactive: close when active (disconnect when inactive);

When input port 1 active or input port 2 active, if input port 3 is active, Defined combination output is outputting; If input port 3 inactive, Defined combination output is not outputting;

When input port 1 inactive and input port 2 inactive, whatever input port 3 is active or not, Defined combination output is not outputting.



### 8.3 DEFINED CONTENTS OF PROGRAMMABLE INPUT PORTS

**Table 15 Definition of Digital Input Ports 1-10 (GND Connected (B-) is active)**

No.	Type	Description
0	Users Configured	Users-defined alarm. Active range: Never: input inactive. Always: input is active all the time. From crank: detecting as soon as start. From safety on: detecting after safety on run delay.
1	Reserved	
2	Alarm Mute	Can prohibit 'Audible Alarm' output when input is active.
3	Reset Alarm	Can reset shutdown, trip and stop, trip, block and warning alarm when input is active.
4	60Hz Active	Use for CANBUS engine and it is 60Hz when input is active.
5	Lamp Test	All LED indicators are illuminated when input is active.
6	Panel Lock	All buttons on panel is inactive except navigation buttons and there is  in the right top corner in LCD when input is active.
7	Reserved	
8	Idle Control Mode	Under voltage/frequency/speed protection is inactive.
9	Auto Stop Inhibit	In <b>Auto</b> mode, during generator normal running, when input is active, prohibit generator shutdown automatically.
10	Auto Start Inhibit	In <b>Auto</b> mode, prohibit generator start automatically when input is active.
11	Scheduled Inhibit	In <b>Auto</b> mode, prohibit scheduled start genset when input is active.
12	Reserved	
13	Gen Closed Aux	Connect generator loading switch's auxiliary point.
14	Gen Load Inhibit	Prohibit genset switch on when input is active.
15	Mains Closed Aux	Connect mains loading switch's auxiliary point.
16	Mains Load Inhibit	Prohibit mains switch close when input is active.
17	Auto Mode Lock	When input is active, controller enters into Auto mode.
18	Auto Mode Inhibit	When input is active, controller won't work under Auto mode. Auto key on the panel and simulate auto key input do not work.
19	Controller Backlit	
20	Controller Buzzer	
21	Alarm Stop Inhibit	All shutdown alarms are prohibited except emergence stop.(Means battle mode or override mode)
22	Instrument Mode	All outputs are prohibited in this mode.
23	Reset Maintenance 1	Controller will set maintenance time and date as default when input is active.
24	Reset Maintenance 2	
25	Reset Maintenance 3	
26	High Temp. Shutdown	Connected sensor digital input.
27	Low OP Shutdown	Connected sensor digital input.



No.	Type	Description
28	Remote Start Onload	In <b>Auto</b> mode, when input is active, genset can be started automatically and takes load after genset is OK; when input inactive, genset will stop automatically.
29	Remote Start Offload	In <b>Auto</b> mode, when input is active, genset can be started automatically and won't take load after genset is OK; when input is inactive, genset will stop automatically.
30	Manual Start Aux	In <b>Auto</b> mode, when input is active, genset will start automatically; when input is inactive, genset will stop automatically.
31	Reserved	
32	Reserved	
33	Simulate Stop Btn	An external button can be connected to simulate as pressed.
34	Simulate Manual Btn	
35	Reserved	
36	Simulate Auto Btn	An external button can be connected to simulate as pressed.
37	Simulate Start Btn	
38	Simulate G-Load Btn	
39	Simulate M-Load Btn	
40	Low Coolant Level	Connect digital input of water level sensor.
41	Detonation Shutdown	Connect alarm input of detection module.
42	Middle Speed	
43	Rated Speed	
44	First Priority	
45	Aux Mains OK	In Auto mode, when input is active, it means Mains is normal.
46	Aux Mains Fail	In Auto mode, when input is active, it means Mains is abnormal; When input is active, alternative configuration is active; Alt. configuration can be set to different parameters for the convenience of users to select current configuration by input selection.
47	Alternative Config 1	When input is active, alt. configuration is active; Users can set different parameters to make it easy to select current configuration via input port.
48	Alternative Config 2	
49	Alternative Config 3	
50	Gas Leak Shutdown	Connect alarm input of detection module.
51	NEL Manual Trip	An external button (Not self-locking) can be connected; For function details please refer to following description.
52	NEL Manual Recon	
53	NEL Manual Connect	An external button (Not self-locking) can be connected; For function details please refer to following description.
54	NEL Manual Trip	
55	Reserved	
56	Reserved	
57	Reserved	
58	Reserved	
59	Reserved	
60	Rise Speed Pulse	When engine type is 35 MTSC1 and input is active, target engine speed rises to 50RPM.



No.	Type	Description
61	Drop Speed Pulse	When engine type is 35 MTSC1 and input is active, target engine speed reduces to 50RPM.
62	Reserved	
63	Reserved	
64	Reserved	
65	Reserved	
66	Reserved	
67	Reserved	
68	Reserved	
69	Reserved	
70	Reserved	

SmartGen

## 8.4 SELECTION OF SENSORS

**Table 16 Sensor Selection**

No.		Description	Remark
1	Temperature Sensor	0 Not used 1 Custom Res Curve 2 Custom (4-20)mA curve 3 Custom (0-10)V curve 4 VDO 5 CURTIS 6 DATCON 7 SGX 8 SGD 9 SGH 10 PT100 11 SUSUKI 12 PRO 13-15 Reserved	Defined resistance's range is (0~6)kΩ. Factory default is SGD sensor.
2	Pressure Sensor	0 Not used 1 Custom Res Curve 2 Custom (4-20)mA curve 3 Custom (0-10)V curve 4 VDO 10Bar 5 CURTIS 6 DATCON 10Bar 7 SGX 8 SGD 9 SGH 10 VDO 5Bar 11 DATCON 5Bar 12 DATCON 7Bar 13 SUSUKI 14 PRO 15 Reserved	Default resistance type; Defined resistance's range is (0~6)kΩ. Default is SGD sensor.
3	Oil Level Sensor	0 Not used 1 Custom Res Curve 2 Custom (4-20)mA curve 3 Custom (0-10)V curve 4 SGD 5 SGH 6~15 Reserved	Defined resistance's range is (0~6)kΩ. Factory default is SGH sensor.

**NOTE:** The input signal of Pressure, Fuel Level, flexible sensor 1, flexible sensor 2 can be resistance, current and voltage.

## 8.5 CONDITIONS OF CRANK DISCONNECT SELECTION

**Table 17 Crank Disconnect Conditions**

No.	Setting Description
0	Frequency
1	Speed
2	Speed + Frequency
3	Oil pressure
4	Oil pressure + Frequency
5	Oil pressure + Speed
6	Oil pressure + Speed + Frequency

### ▲NOTES:

- 1) There are 3 conditions to make starter disconnected with engine, that is, speed, frequency and engine oil pressure. They all can be used separately. We recommend that engine oil pressure should be used with speed and generator frequency together, in order to make the starter motor separated with engine immediately and can check crank disconnect exactly.
- 2) Speed sensor is the magnetic equipment which is installed in starter for detecting flywheel teeth.
- 3) When it is set as speed sensor, users must ensure that the number of flywheel teeth is the same as setting, otherwise, "over speed stop" or "under speed stop" may be caused.
- 4) If genset is without magnetic sensor, please don't select corresponding items, otherwise, "start fail" or "loss speed signal" may be caused.
- 5) If genset is without oil pressure sensor, please don't select corresponding items.
- 6) If speed sensor is not selected in crank disconnect setting, the speed displayed on controller is calculated by generating signals.

## 9 PARAMETERS SETTING

Please change the controller parameters when generator is in standby mode only (e. g. Start conditions selection, configurable input, configurable output, various delay etc.), otherwise, alarming to stop and other abnormal conditions may happen.

▲NOTE: Maximum set value must over minimum set value in case that the condition of too high as well as too low will happen.

▲NOTE: When the warning alarm is set, please set the correct return value; otherwise, maybe there is abnormal alarm. When the maximum value is set, the return value must be less than the set value; when the minimum value is set, the return value must be over the set value.

▲NOTE: Please set the generator frequency value as low as possible when the genset is cranking, in order to make the starter separated quickly as soon as crank disconnection happens.

▲NOTE: Configurable input could not be set as the same items; otherwise, there are abnormal functions. However, the configurable output can be set as the same items.



## 10 CYCLE START

Cycle start is to control two gensets to start circularly. Two gensets are connected by CAN(2) or RS485(2). Master can control backup to start/stop genset by sending commands and check backup fault status. Master and backup can be set by parameter configurations, or decided by input setting. It is only active in Auto mode.

Operation procedure:

- a) Master waits for start and when remote start input is active, it starts automatically. Running time is the pre-set "Master Running" time;
- b) "Master Running" is over or shutdown alarm occurs; and when backup remote start input is active, backup starts; when backup runs normally, master stops; backup running time is the pre-set "Obey Running" time;
- c) In the whole process, master and backup can change current status information at real time by CAN(2) and RS485(2); when running time is over or backup shutdown alarm occurs, master starts and it goes like this circularly;
- d) When communication is interrupted, controller issues "Cycle Com Fail" alarm; when master remote start input is active, master starts; when backup remote start input is active, backup starts.

## 11 SENSOR SETTING

- 1) When sensors are reselected, the sensor curves will be transferred into the standard value. For example, if temperature sensor is SGH (120°C resistor type), its sensor curve is SGH (120°C resistor type); if select the SGD (120°C resistor type), the temperature sensor curve is SGD curve.
- 2) When there is difference between standard sensor curves and used sensor curves, users can select custom sensor curve and input self defined sensor curve.
- 3) When the sensor curve is inputted, x value (resistor) must be inputted from small to large, otherwise, mistake occurs.
- 4) If sensor type is selected as "none", sensor curve is not working.
- 5) If the corresponding sensor has alarm switch only, users must set this sensor as "none", otherwise, shutdown or warning may occur.
- 6) The headmost or backmost values in the vertical coordinates can be set as the same as below.

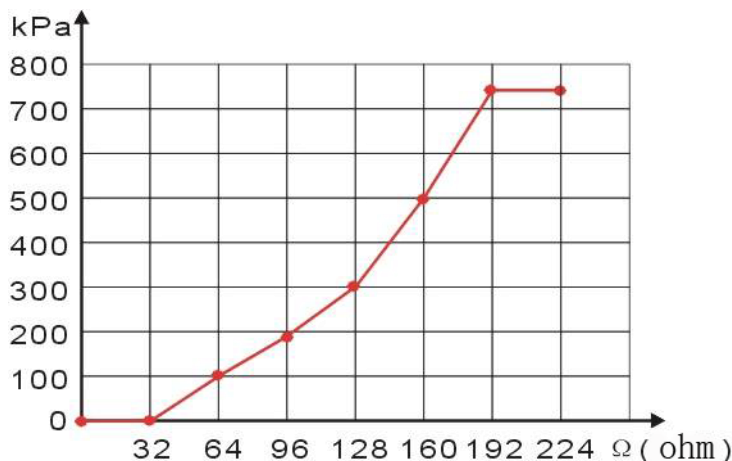

Fig. 5 Sensor Curve Diagram



**Table 18 Normal Pressure Unit Conversion Form**

	pa	kgf/cm <sup>2</sup>	bar	psi
1Pa	1	$1.02 \times 10^{-5}$	$1 \times 10^{-5}$	$1.45 \times 10^{-4}$
1kgf/cm <sup>2</sup>	$9.8 \times 10^4$	1	0.98	14.2
1bar	$1 \times 10^5$	1.02	1	14.5
1psi	$6.89 \times 10^3$	$7.03 \times 10^{-2}$	$6.89 \times 10^{-2}$	1

SmartGen

## 12 COMMISSIONING

Please make sure the following checks are made before commissioning,

- Ensure all the wiring connections are correct and wire diameter is suitable.
- Ensure that the controller DC power has fuse, and controller's positive and negative and start battery are correctly connected.
- Emergency stop input is connected to the positive pole of starter battery via emergency stop button's normally closed point and fuse.
- Take proper actions to prevent engine from cranking successfully (e. g. Remove the connection wire of fuel valve). If checking is OK, make the start battery power on; choose manual mode and controller will executive routine.
- Set controller under manual mode, press "start" button, and genset will start. After the cranking times set before, controller will send signal of Start Failure; then press "stop" to reset controller.
- Recover the action to prevent engine from cranking successfully (e. g. Connect wire of fuel valve), press start button again, and genset will start. If everything goes well, genset will be normally running after idle running (if idle run is set). During this time, please watch engine's running situation and AC generator's voltage and frequency. If there is something abnormal, stop genset and check all wiring connections according to this manual.
- Select the **AUTO** mode from controller's panel, and connect mains signal. After the mains normal delay, controller will transfer ATS (if set) into mains onload. After cooling time, controller will stop genset and make it into "at rest" mode until there is mains abnormal situation.
- When mains is abnormal again, genset will be started automatically and enter into normal running, then controller send signal to make generator switch on, and control the ATS transfer into generator load. If it is not like this, please check ATS wiring connection according to this manual.
- If there is any other question, please contact SmartGen's service.

**13 TYPICAL APPLICATION**

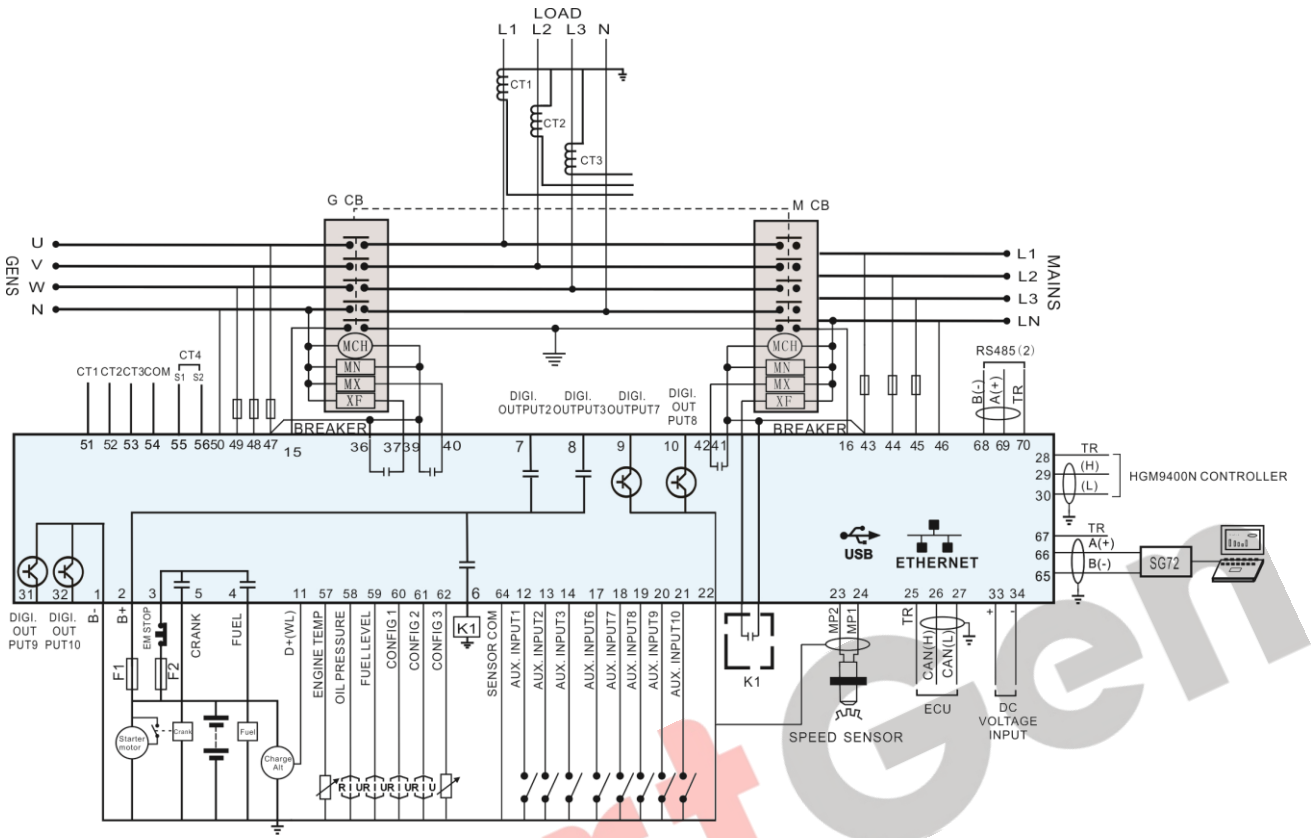

**Fig. 6 HGM9420N\_HGM9420LT Sync Transfer Typical Application Diagram**

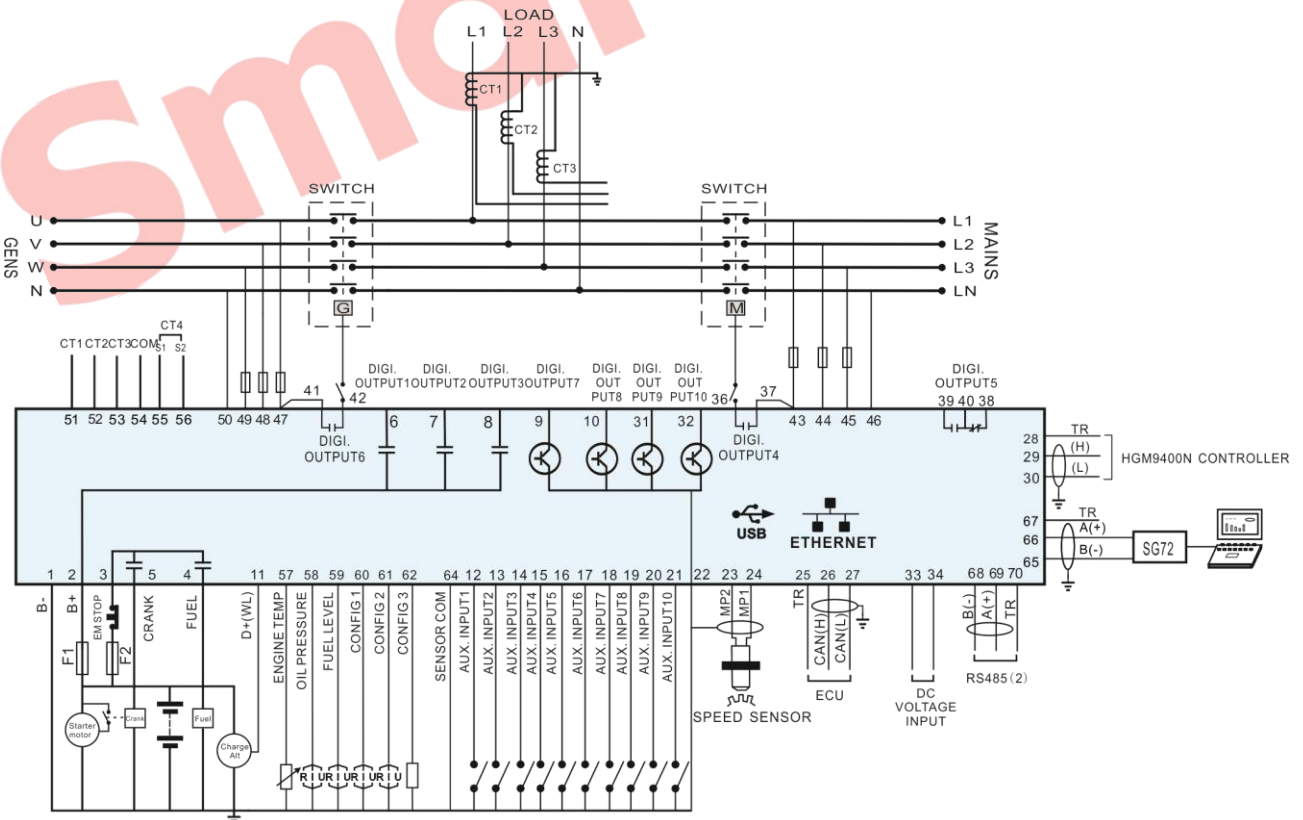

**Fig. 7 HGM9420N\_HGM9420LT Typical Application Diagram**

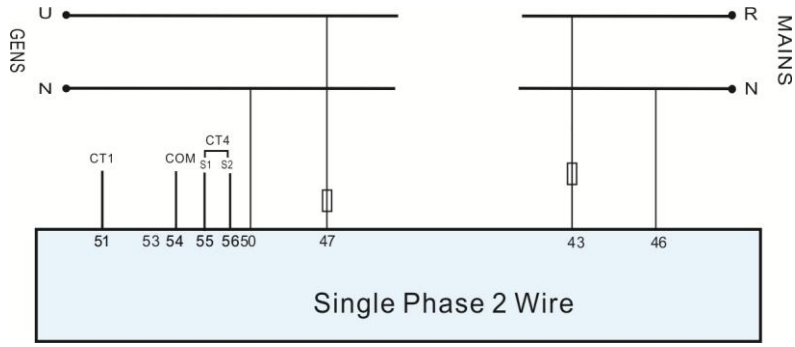

**Fig. 8 Single Phase 2-Wire Wiring Diagram**

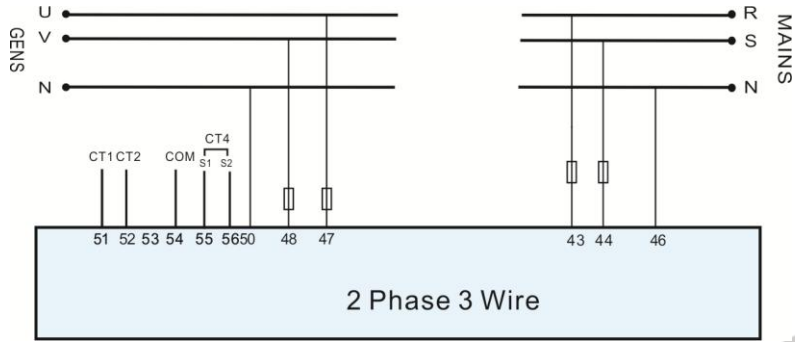

**Fig. 9 2-Phase 3-Wire Wiring Diagram**

**NOTE:** It is recommended to expand large capacity relay for Crank, and Fuel output terminals.

## 14 NEL TRIP DESCRIPTION

Non-essential Load---NEL is the abbreviation.

The controller can control the NEL1, NEL2 and NEL3 to trip separately. The order of the essentiality is: NEL3 > NEL2 > NEL1

### ◆ Auto Trip:

When NEL auto trip is enabled:

If the genset power has exceeded the NEL trip value, after the trip delay, NEL1 will trip the earliest, and then is NEL2, NEL3;

When NEL auto reconnection is enabled:

If the genset power has fallen below the auto reconnection set value, after the auto reconnection delay, NEL3 will reconnect the earliest, and then is NEL2, NEL1;

t1: NEL Trip Delay  
t2: Reconnection Delay

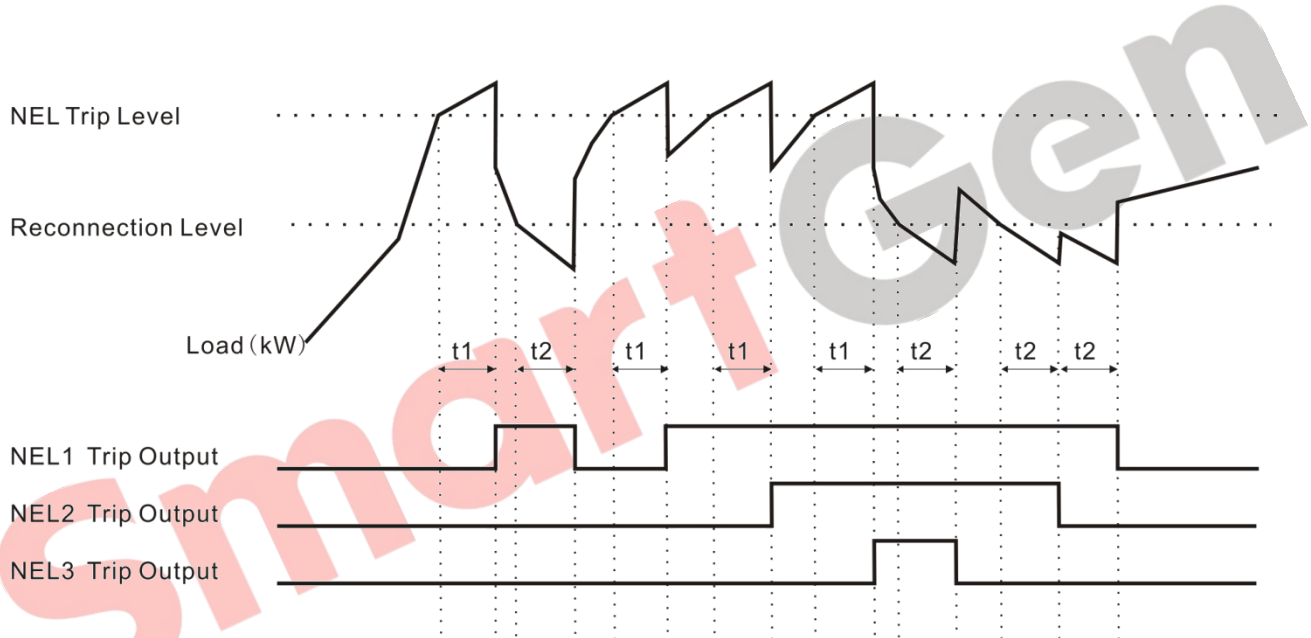

**Fig. 10 NEL Sequence**

### ◆ Manual Trip

If NEL manual trip input is active (earthed falling edge is active), NEL1 will trip without delay; If NEL manual trip input is active again, NEL2 will trip; If NEL manual trip input is active the third time, NEL3 will trip.

If NEL manual reconnection input is active (earthed falling edge is active), NEL3 will reconnect without delay; If NEL manual reconnection input is active again, NEL2 will reconnect; If NEL manual reconnection input is active for the third time, NEL1 will reconnect. During this process, the genset power judges if the genset power has fallen below the NEL reconnection value. If genset power is less than NEL reconnection value, then the input is active; otherwise the input is deactivated.

**▲NOTE:** When auto trip and auto reconnection are enabled, manual trip is still active.



## 15 DUMMY LOAD CONNECTION

Dummy Load ---- DL for short.

The controller can control the 3 ways of DL connect separately. The order of the essentiality is: DL1 > DL2 > DL3

◆ Auto operation:

When DL auto connect is enabled:

If the genset power has fallen below the DL connection value, after the connection delay, DL1 will connect the earliest, and then is DL2, DL3;

When DL auto disconnect is enabled:

If the genset power has exceed the DL disconnect value, after the disconnect delay, DL3 will disconnect the earliest, and then is DL2, DL1;

t1: DL Connection Delay

t2: DL Disconnect Delay

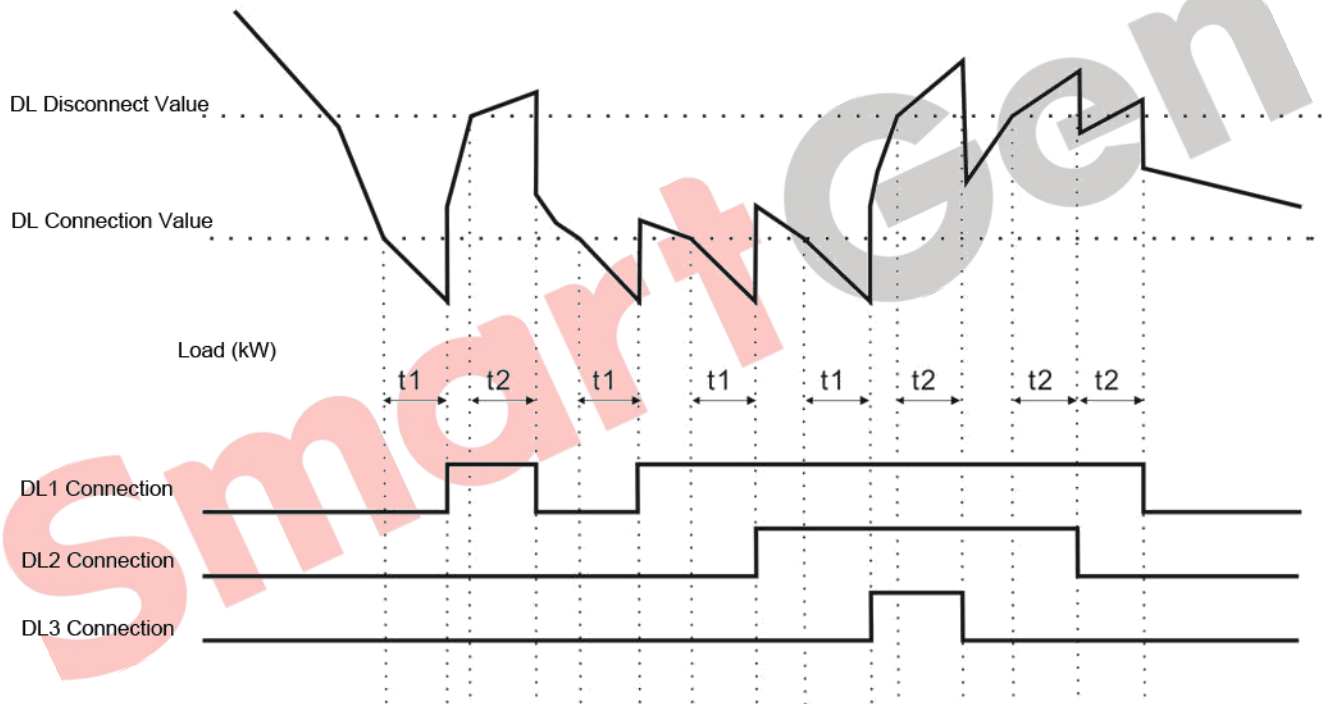

**Fig. 11 DL Sequence**

◆ Manual Operation

If manual DL connect input is active (earthed failing edge is active), DL1 will connect without delay; If manual DL connect input is active again, DL2 will connect; If manual DL connect input is active the third time, DL3 will connect. During this process, the controller will detect if the genset power has fallen the DL connection value or not. If genset power is below DL connection value, this input is active, otherwise, it will be ignored.

If manual DL disconnect input is active (earthed failing edge is active), DL3 will disconnect without delay; If manual DL disconnect input is active again, DL2 will disconnect; If manual DL disconnect input is active the third time, DL1 will disconnect.

**▲NOTE:** When auto connection and auto disconnection are enabled, manual operation is still active.

## 16 OIL CONSUMPTION ILLUSTRATION

Oil consumption parameters include: oil tank remaining fuel, real time oil consumption, fuel remaining time.

Remaining fuel is calculated by fuel level sensor value and the pre-set oil tank volume.

Real-time oil consumption is calculated by real-time active power and oil consumption curve. About oil consumption curve settings, set genset power and the corresponding oil consumption volume per hour, set curve X axis (1-8) points to genset power (kW), and set curve Y axis (1-8) points to genset oil consumption volume per hour. Real-time oil consumption is as below:

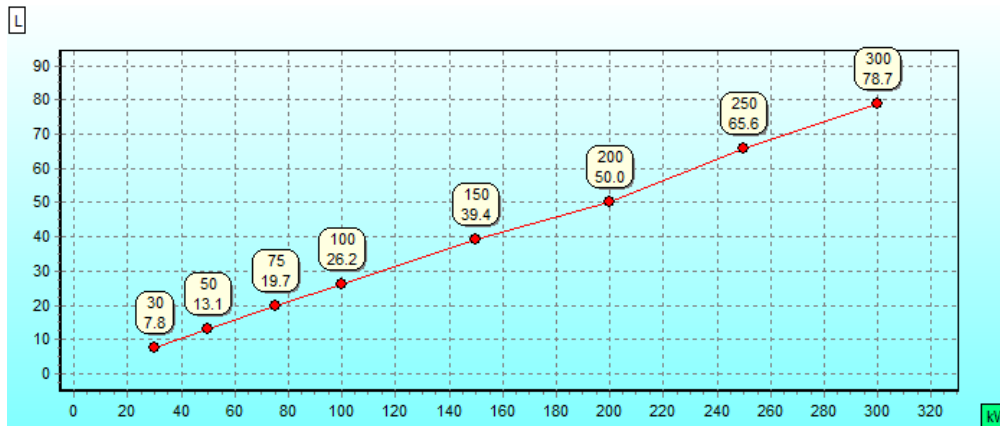

**Fig. 12 Oil Consumption Curve**

Fuel remaining time is equal to the remaining fuel dividing genset oil consumption per hour.

**NOTE:** It needs to enable Fuel Level Sensor, Oil Tank Capacity, Real-time Oil Consumption Curve.

## 17 ETHERNET PORT

Ethernet port can be used to monitor the controller, which can realize network client terminal connection.

**NOTE:** After changing network setting parameters (IP address, subnet mask etc.) of the controller, it needs to power on the controller again, so that new parameter settings can be valid.

As network client, controller can be monitored via network port by TCP/IP Modbus protocol by users.

Steps are as below:

1. Set controller IP address and subnet mask, the set IP address needs to be in the same stage with monitoring device (PC), but they are different. For example: IP address of monitoring device is 192.168.0.16, then IP address of controller needs to set to 192.168.0.18, and subnet mask is 255.255.255.0.
2. Connect controller. Users can directly use network wire to connect monitoring device and controller; interchanger is Okay as well.
3. Monitoring device uses TCP Modbus protocol to communicate with controller.

**NOTE:** Controller parameters can be set in this connection mode. Test software of our company can connect in this way.

Ask for the communication protocol from our company personnel.

## 18 HOST USB PORT

HGM9420N\_HGM9420LT controller supports to insert U flash of FAT32 format. By inserting U flash, it can realize:

◆ Lead-in and lead-out function of configured parameters

1. Check xxx.glm configuration files in the U flash;
2. Upload configuration files of HGM9400NXXXX.lgm format to controller;
3. Save controller configuration parameters to corresponding HGM9400NXXXX.lgm file;
4. Save new configuration file (HGM9400NXXXX.lgm).

◆ Historical data saving

Historical data saving files are named by year and month. For.dat files named by year-month-day, genset saves data per minute at standby status, at other statuses data are saved per second. If the memory room in the U flash is less than or equal to 200MB, then the earliest month memory files will be deleted.

Historical data files are as below:

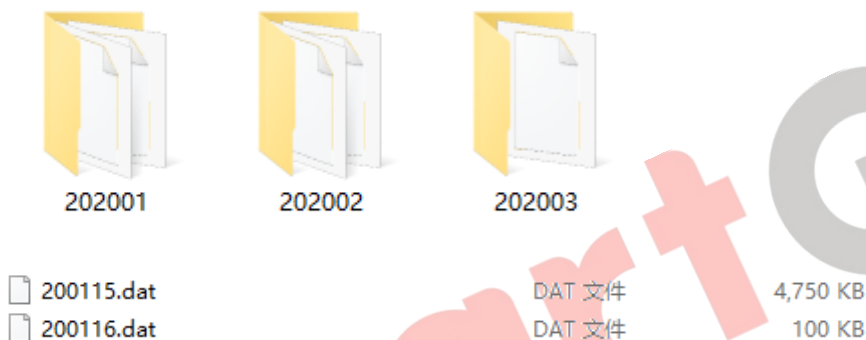

Historical data curves can be checked by the historical data analysis function of data iGMP6 software.

## 19 INSTALLATION

### 19.1 SGE02 EXPANSION MODULE

#### 19.1.1 4G ANTENNA PORT

Connect 4G antenna with 4G port of SGE02.

Antenna port: 50Ω/SMA connector.

#### 19.1.2 GPS ANTENNA PORT

By using GPS function, connect GPS antenna and GPS port of SGE02.

**NOTE:** GPS antenna needs to be put outdoor, otherwise location information is not correct or users cannot obtain location information.

Antenna port: 50Ω/SMA receptacle, active antenna.

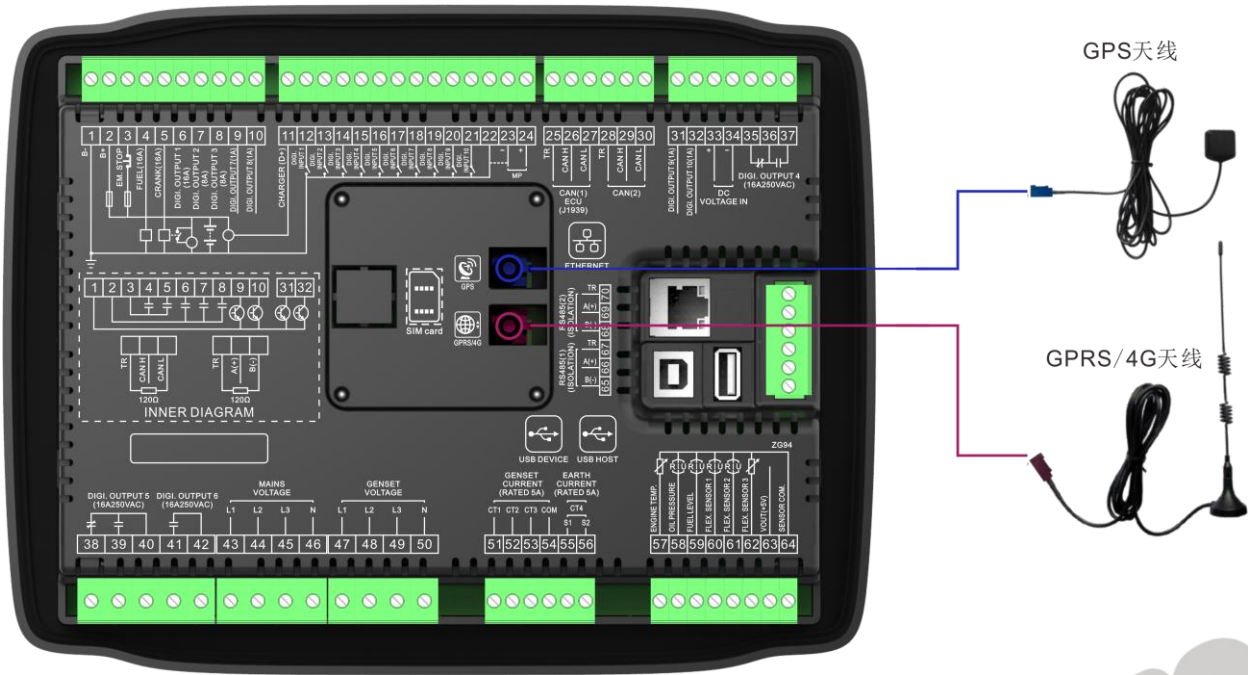



Fig. 13 SGE02 Antenna Connection

### 19.1.3 SIM CARD INSTALLATION

Insert 4G, 3G or 2G SIM card, controller will connect the server by wireless mobile network.

**NOTE:** This module supports Netcom 4G wireless network, applying standard SIM card (dimension 25mmx15mm); if controller displays  mark, it means SIM card is not in, or SIM card is poor contact.

Installation Step is as below.

1. Open the cover.
2. Insert SIM card.
3. Lock SIM card.
4. Install the cover.



Fig. 14 SIM Card Installation Method

### 19.2 CASE DIMENSIONS AND CUTOUT SIZE

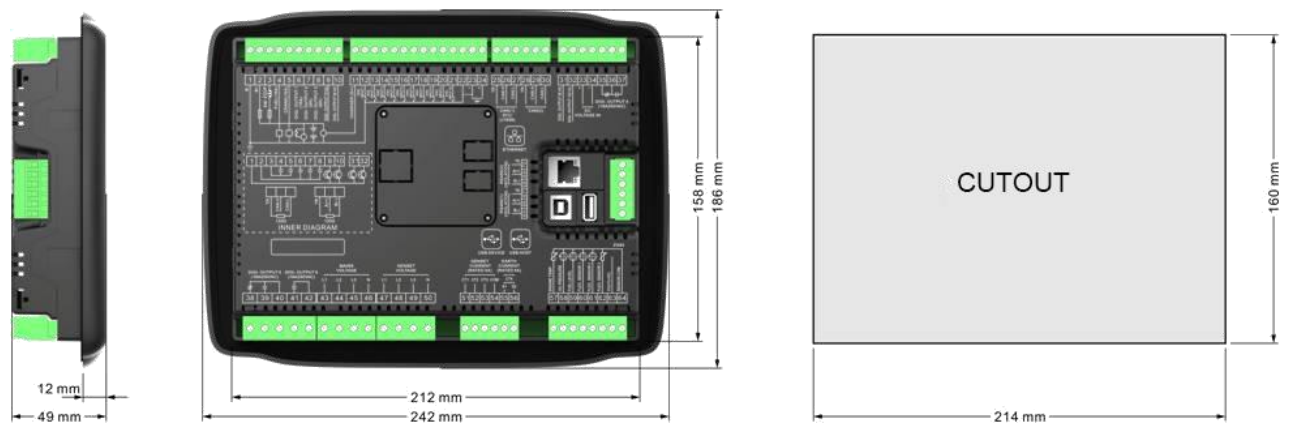

Fig. 15 Dimension and Cutout Size

HGM9420N\_HGM9420LT controller can suit for (8~35) VDC battery voltage environment. Battery negative electrode must be connected with the starter shell stably. The wire area connecting controller power B+/B- with negative and positive electrodes of battery mustn't be less than  $2.5\text{mm}^2$ . If floating charger is configured, please firstly connect output wires of charger to battery's positive and negative directly, and then connect wires from battery's positive and negative to controller's positive and negative input ports separately in order to prevent the charger from disturbing the controller's normal working.

- **Speed Sensor Input:** Speed sensor is the magnetic equipment installed in the engine body to detect flywheel teeth number. The wires used to connect with the controller shall be 2-core shielding wires. The shielding layer shall be connected to No. 23 terminal on the controller, and meanwhile the other terminal shall be hanging in the air. Another two signal wires shall be connected to No.23 and No.24 terminals on the controller. The output voltage of the speed sensor shall be within (1~24) VAC (effective value) in the range of full speed and 12VAC is recommended (at rated speed). As to speed sensor installation, the sensor can firstly be spun to the connection flywheel, then invert 1/3 lap, and finally tighten up the screw on the sensor.
- **Output And Expand Relays:** All controller outputs are relay contact outputs. If the expansion relay is needed, freewheel diode (relay coil is DC) and resistor and capacitor circuit (relay coil is AC) shall be added to the two ends of the relay coils in order to prevent disturbing the controller or others equipments.
- **Alternate Current Input:** HGM9420N\_HGM9420LT controller current input must be connected to outside current transformer. The secondary side current of the current transformer must be 5A and at the same time current transformer phase and input voltage phase must be correct, otherwise the collected current and active power may not be correct.
- **Withstand Voltage Test:** When controller had been installed in control panel, if high voltage test is needed, please disconnect controller's all terminal connections, in order to prevent high voltage into controller and damage it.

▲NOTE 1: ICOM port must be connected to negative pole of battery.

▲NOTE 2: When there is load current, transformer's secondary side is prohibited open circuit.



## 20 SMS MESSAGE ALARM AND REMOTE CONTROL

### 20.1 SMS MESSAGE ALARM

When controller detects alarms, it will send message automatically to the pre-set telephone numbers.

**NOTE:** All shutdown alarms, trip and stop alarms, trip alarms can send messages to the pre-set telephone numbers. For warning alarms, controller will send messages to the phone according to user configurations.

### 20.2 SMS MESSAGE REMOTE CONTROL

Users send message commands to wireless communication module, then controller will execute related actions based on message commands, and return related execution information. Controller only executes the message commands from its own pre-set phone numbers. Detailed message commands are as below.

**Table 19 SMS Message Order List**

No.	Message Command	Message Return Information	Description
1	SMS GENSET	GENSET ALARM	Genset stop alarm or trip and stop alarm
		SYSTEM IN STOP MODE GENSET AT REST	In stop mode, standby status
		SYSTEM IN MANUAL MODE GENSET AT REST	In manual mode, standby status
		SYSTEM IN AUTO MODE GENSET AT REST	In auto mode, standby status
		SYSTEM IN STOP MODE GENSET IS RUNNING	In stop mode, start status
		SYSTEM IN MANUAL MODE GENSET IS RUNNING	In manual mode, start status
		SYSTEM IN AUTO MODE GENSET IS RUNNING	In auto mode, start status
2	SMS START	GENSET ALARM	Genset stop alarm or trip and stop alarm
		STOP MODE NOT START	In stop mode, cannot start
		SMS START OK	In manual mode, is starting
		AUTO MODE NOT START	In auto mode, cannot start
3	SMS STOP MODE	SMS STOP OK	Set to stop mode
4	SMS MANUAL MODE	SMS MANUAL MODE OK	Set to manual mode
5	SMS AUTO MODE	SMS AUTO MODE OK	Set to auto mode
6	SMS DETAIL	Return information can be set by software.	Obtain genset details.

**NOTE:** Users shall send commands according to the contents of above table. All letters shall be capital.



**NOTE:** SMS DETAIL returned detailed information includes: working mode, Mains voltage, Gen voltage, load current, Mains frequency, Gen frequency, active power, apparent power, power factor, battery voltage, D+ voltage, water temperature, oil pressure, fuel level, speed, accumulated running time, genset status, alarm status.

## 21 CONNECTIONS OF CONTROLLER AND J1939 ENGINE

### 21.1 CUMMINS ISB/ISBE

**Table 20 Connector B**

Terminals of controller	Connector B	Remark
Aux. output 1	39	Configured to "Fuel Output";
Start relay output	-	Connected with starter coil directly;
Aux. output 2	Expansion 30A relay; providing battery voltage for terminal 01,07,12,13;	Set to "ECU power";

**Table 21 9-Pin Connector**

Terminals of controller	9 pins connector	Remark
CAN_SCR	SAE J1939 shield	CAN communication shielding line (connected with ECU terminal only);
CAN(H)	SAE J1939 signal	Impedance 120Ω connecting line is recommended.
CAN(L)	SAE J1939 return	Impedance 120Ω connecting line is recommended.

Engine type: Cummins ISB.

### 21.2 CUMMINS QSL9

Suitable for CM850 engine control module.

**Table 22 50-Pin Connector**

Terminals of controller	50 pins connector	Remark
Aux. output 1	39	Configured to "Fuel Output";
Start relay output	-	Connected to starter coil directly;

**Table 23 9-Pin Connector**

Terminals of controller	9 pins connector	Remark
CAN_SCR	SAE J1939 shield-E	CAN communication shielding line (connected with ECU terminal only);
CAN(H)	SAE J1939 signal-C	Using impedance 120Ω connecting line;
CAN(L)	SAE J1939 return-D	Using impedance 120Ω connecting line;

Engine type: Cummins-CM850.

### 21.3 CUMMINS QSM11 (IMPORT)

It is suitable for CM570 engine control module. Engine type is QSM11 G1, QSM11 G2.

**Table 24 C1 Connector**

Terminals of controller	C1 connector	Remark
Aux. output 1	5&8	Configured to "Fuel Output"; External expansion relay; at fuel output, make port 5 and port 8 of C1 connector connected;
Start relay output	-	Connected to starter coil directly;

**Table 25 3-Pin Data Link Connector**

Terminals of controller	3 pins data link connector	Remark
CAN_SCR	C	CAN communication shielding line (connected with ECU terminal only);
CAN(H)	A	Using impedance 120Ω connecting line;
CAN(L)	B	Using impedance 120Ω connecting line;

Engine type: Cummins ISB.

### 21.4 CUMMINS QSX15-CM570

It is suitable for CM570 engine control module. Engine type is QSX15 etc.

**Table 26 50-Pin Connector**

Terminals of controller	50 pins connector	Remark
Aux. output 1	38	Injection switch; Configured to "Fuel Output";
Start relay output	-	Connected to starter coil directly;

**Table 27 9-Pin Connector**

Terminals of controller	9 pins connector	Remark
CAN_SCR	SAE J1939 shield-E	CAN communication shielding line (connected with ECU terminal only);
CAN(H)	SAE J1939 signal-C	Using impedance 120Ω connecting line;
CAN(L)	SAE J1939 return-D	Using impedance 120Ω connecting line;

Engine type: Cummins QSX15-CM570.

## 21.5 CUMMINS GCS-MODBUS

It is suitable for GCS engine control module. Use RS485-MODBUS to read information of engine. Engine types are QSX15, QST30, QSK23/45/60/78 and so on.

**Table 28 D-SUB Connector 06**

Terminals of controller	D-SUB connector 06	Remark
Aux. output 1	5&8	Configured to "Fuel Output"; Outside expansion relay; at fuel output, make port 05 and port 08 of connector 06 connected.
Start relay output	-	Connected to starter coil directly;

**Table 29 D-SUB Connector 06**

Terminals of controller	D-SUB connector 06	Remark
RS485 GND	20	CAN communication shielding line (connected with ECU terminal only);
RS485+	21	Using impedance 120Ω connecting line;
RS485-	18	Using impedance 120Ω connecting line;

Engine type: Cummins-QSK-MODBUS, Cummins- QST-MODBUS, Cummins-QSX-MODBUS.

## 21.6 CUMMINS QSM11

**Table 30 Engine OEM Connector**

Terminals of controller	OEM connector of engine	Remark
Aux. output 1	38	Configured to "Fuel Output";
Start relay output	-	Connected with starter coil directly;
CAN_SCR	-	CAN communication shielding line
CAN(H)	46	Using impedance 120Ω connecting line;
CAN(L)	37	Using impedance 120Ω connecting line;

Engine type: Common J1939.

## 21.7 CUMMINS QSZ13

**Table 31 Engine OEM Connector**

Terminals of controller	OEM connector of engine	Remark
Aux. output 1	45	
Start relay output	-	Connected to starter coil directly;
Aux. output 2	16&41	Set as idling speed control; (N/C) output; by expansion relay, make 16&41 close as the controller is running.
Aux. output 3	19&41	Set as pulse speed raising control; (N/O) output; by expansion relay, make 19&41 close for 1s as the controller is entering warming-up time.
CAN_SCR	-	CAN communication shielding line
CAN(H)	1	Using impedance 120Ω connecting line;
CAN(L)	21	Using impedance 120Ω connecting line;

Engine type: Common J1939.

**21.8 DETROIT DIESEL DDEC III/IV**
**Table 32 Engine CAN Port**

Terminals of controller	CAN port of engine	Remark
Aux. output 1	Expansion 30A relay, proving battery voltage for ECU;	Configured to "Fuel Output";
Start relay output	-	Connected to starter coil directly;
CAN_SCR	-	CAN communication shielding line
CAN(H)	CAN(H)	Using impedance 120Ω connecting line;
CAN(L)	CAN(L)	Using impedance 120Ω connecting line;

Engine type: Common J1939.

**21.9 DEUTZ EMR2**
**Table 33 F Connector**

Terminals of controller	F connector	Remark
Aux. output 1	Expansion 30A relay, proving battery voltage for terminal 14; Fuse is 16A.	Configured to "Fuel Output";
Start relay output	-	Connected to starter coil directly;
-	1	Connected to battery negative;
CAN_SCR	-	CAN communication shielding line
CAN(H)	12	Impedance 120Ω connecting line is recommended.
CAN(L)	13	Impedance 120Ω connecting line is recommended.

Engine type: Volvo EDC4.

**21.10 JOHN DEERE**
**Table 34 21-Pin Connector**

Terminals of controller	21 pins connector	Remark
Aux. output 1	G, J	Configured to "Fuel Output";
Start relay output	D	
CAN_SCR	-	CAN communication shielding line
CAN(H)	V	Using impedance 120Ω connecting line;
CAN(L)	U	Using impedance 120Ω connecting line;

Engine type: John Deere.

## 21.11 MTU MDEC

Suitable for MTU engines 2000 series, 4000series.

**Table 35 X1 Connector**

Terminals of controller	X1 Connector	Remark
Aux. output 1	BE1	Configured to "Fuel Output";
Start relay output	BE9	
CAN_SCR	E	CAN communication shielding line
CAN(H)	G	Using impedance 120Ω connecting line;
CAN(L)	F	Using impedance 120Ω connecting line;

Engine type: mtu-MDEC-303.

## 21.12 MTU ADEC(SMART MODULE)

It is suitable for MTU engine with ADEC (ECU8) and SMART module.

**Table 36 ADEC (X1 Connector)**

Terminals of controller	ADEC (X1port)	Remark
Aux. output 1	X1 10	Configured to "Fuel Output"; X1 9 shall connect negative of battery.
Start relay output	X1 34	X1 33 shall connect negative of battery.

**Table 37 SMART (X4 Connector)**

Terminals of controller	SAM (X23 port)	Remark
CAN_SCR	X4 3	CAN communication shielding line
CAN(H)	X4 1	Using impedance 120Ω connecting line;
CAN(L)	X4 2	Using impedance 120Ω connecting line;

Engine type: mtu-ADEC.

## 21.13 MTU ADEC (SAM MODULE)

Suitable for MTU engine with ADEC (ECU7) and SAM module.

**Table 38 ADEC (X1 Port)**

Terminals of controller	ADEC (X1 port)	Remark
Aux. output 1	X1 43	Configured to "Fuel Output"; X1 28 shall connect negative of battery.
Start relay output	X1 37	X1 22 shall connect negative of battery.

**Table 39 SAM (X23 Port)**

Terminals of controller	SAM (X23 Port)	Remark
CAN_SCR	X23 3	CAN communication shielding line
CAN(H)	X23 2	Using impedance 120Ω connecting line;
CAN(L)	X23 1	Using impedance 120Ω connecting line;

Engine type: Common J1939.

## 21.14 PERKINS

It is suitable for ADEM3/ ADEM4 engine control module. Engine type is 2306, 2506, 1106, and 2806.

**Table 40 Connector**

Terminals of controller	Connector	Remark
Aux. output 1	1,10,15,33,34	Configured to "Fuel Output";
Start relay output	-	Connected to starter coil directly;
CAN_SCR	-	CAN communication shielding line
CAN(H)	31	Using impedance 120Ω connecting line;
CAN(L)	32	Using impedance 120Ω connecting line;

Engine type: Perkins.

## 21.15 SCANIA

It is suitable for S6 engine control module. Engine type is DC9, DC12, and DC16.

**Table 41 B1 Connector**

Terminals of controller	B1 connector	Remark
Aux. output 1	3	Configured to "Fuel Output";
Start relay output	-	Connected to starter coil directly;
CAN_SCR	-	CAN communication shielding line
CAN(H)	9	Using impedance 120Ω connecting line;
CAN(L)	10	Using impedance 120Ω connecting line;

Engine type: Scania.

## 21.16 VOLVO EDC3

Suitable engine control mode is TAD1240, TAD1241, and TAD1242.

**Table 42 "Stand Alone" Connector**

Terminals of controller	"Stand alone" connector	Remark
Aux. output 1	H	Configured to "Fuel Output";
Start relay output	E	
Aux. output 2	P	Set to "ECU power";

**Table 43 "Data Bus" Connector**

Terminals of controller	"Data bus" connector	Remark
CAN_SCR	-	CAN communication shielding line
CAN(H)	1	Using impedance 120Ω connecting line;
CAN(L)	2	Using impedance 120Ω connecting line;

Engine type: Volvo.

**NOTE:** When this engine type is selected, preheating time should be set to at least 3 seconds.



## 21.17 VOLVO EDC4

Suitable engine types are TD520, TAD520 (optional), TD720, TAD720 (optional), TAD721, TAD722, and TAD732.

**Table 44 Connector**

Terminals of controller	Connector	Remark
Aux. output 1	Expansion 30A relay, providing battery voltage for terminal 14. Fuse is 16A.	Configured to "Fuel Output";
Start relay output	-	Connected to starter coil directly;
	1	Connected to negative of battery;
CAN_SCR	-	CAN communication shielding line;
CAN(H)	12	Using impedance 120Ω connecting line;
CAN(L)	13	Using impedance 120Ω connecting line;

Engine type: Volvo EDC4.

## 21.18 VOLVO-EMS2

Volvo Engine types are TAD734, TAD940, TAD941, TAD1640, TAD1641, and TAD1642.

**Table 45 Engine CAN Port**

Terminals of controller	Engine's CAN port	Remark
Aux. output 1	6	Set output 1 to "ECU stop";
Aux. output 2	5	Set output 2 to "ECU power";
	3	Power negative;
	4	Power passive;
CAN_SCR	-	CAN communication shielding line;
CAN(H)	1(Hi)	Using impedance 120Ω connecting line;
CAN(L)	2(Lo)	Using impedance 120Ω connecting line;

Engine type: Volvo-EMS2.

**▲NOTE:** When this engine type is selected, preheating time should be set to at least 3 seconds.

## 21.19 YUCHAI

It is suitable for BOSCH common rail engine.

**Table 46 Engine 42-Pin Port**

Terminals of controller	Engine 42 pins port	Remark
Aux. output 1	1.40	Configured to "Fuel Output"; Connected to engine ignition lock;
Start relay output	-	Connected to starter coil directly;
CAN_SCR	-	CAN communication shielding line;
CAN(H)	1.35	Using impedance 120Ω connecting line;
CAN(L)	1.34	Using impedance 120Ω connecting line;

**Table 47 Engine 2-Pin**

Battery	Engine 2 pins	Remark
Battery negative	1	Wire diameter 2.5mm <sup>2</sup> ;
Battery positive	2	Wire diameter 2.5mm <sup>2</sup> ;

Engine type: BOSCH.

## 21.20 WEICHAJ

It is suitable for Weichai BOSCH common rail engine.

**Table 48 Engine Port**

Terminals of controller	Engine port	Remark
Aux. output 1	1.40	Configured to "Fuel Output"; Connected to engine ignition lock;
Start relay output	1.61	
CAN_SCR	-	CAN communication shielding line;
CAN(H)	1.35	Using impedance 120Ω connecting line;
CAN(L)	1.34	Using impedance 120Ω connecting line;

Engine type: GTSC1.

**▲NOTE:** If there is any question of connection between controller and ECU communication, please feel free to contact SmartGen's service.

## 22 FAULT FINDING

**Table 49 Fault Finding**

Symptoms	Possible Solutions
Power on but no response for the controller	Check starting batteries; Check controller connection wirings; Check DC fuse.
Genset shutdown	Check the water/cylinder temperature is too high or not; Check the genset AC voltage; Check DC fuse.
Controller emergency stop	Check emergence stop button is correct or not; Check whether the starting battery positive is connected with the emergency stop input; Check whether there is open circuit.
Low oil pressure alarm after crank disconnect	Check the oil pressure sensor and its connections.
High water temperature alarm after crank disconnect	Check the temperature sensor and its connections.
Shutdown alarm in running	Check related switch and its connections according to the information on LCD; Check digital inputs.
Crank disconnect failure	Check fuel circuit and its connections; Check starting batteries; Check speed sensor and its connections; Refer to engine manual.
No response for starter	Check starter connections; Check starting batteries.
Genset is running but ATS does not transfer.	Check ATS; Check the connections between ATS and controllers.
RS485 communication is abnormal.	Check connections; Check settings of COM port is correct or not; Check RS485's A and B connections is reversely connected or not; Check RS485 transfer model is damaged or not; Check communication port of PC is damaged or not.
ECU communication failure	Check the polarity of CAN high and CAN low; Check 120Ω terminal resistor is correctly connected or not; Check engine type is correctly chosen or not; Check communication port of PC is damaged or not.
ECU alarm	Get information from LCD alarm page; If there is detailed alarm information, check the engine according to the description. If not, please refer to engine manual according to SPN alarm code.

**23 APPENDIX**
**Table 50 SGE02-4G Order Model**

Order Model	Country/Area	Frequency Band	Remark
SGE02-4G	Chinese Mainland	FDD-LTE: B1/B3/B8 TDD-LTE: B38/B39/B40/B41 TD-SCDMA: B34/B39 WCDMA: B1/B8 EVDO/CDMA: BC0 GSM: 900/1800MHz	
SGE02-4G-S01	North America	FDD-LTE: B2/B4/B12 WCDMA: B2/B5	
SGE02-4G-S02		FDD-LTE: B2/B4/B5/B13	
SGE02-4G-S03	Europe/Africa/ Korea/Thailand/ Middle East	FDD-LTE: B1/B3/B5/B7/B8/B20 TDD-LTE: B38/B40/B41 WCDMA: B1/B5/B8 GSM: 900/1800MHz	
SGE02-4G-S04	South America/ Australia/ New Zealand	FDD-LTE: B1/B2/B3/B4/B5/B7/B8/B28 TDD-LTE: B40 WCDMA: B1/B2/B5/B8 GSM: 850/900/1800/1900MHz	
SGE02-4G-S05	Japan	FDD-LTE: B1/B3/B8/B18/B19/B26	